

# **Oracle® Shop Floor Management**

User's Guide

Release 11*i*

**Part No. A83717-07**

March 2005

Oracle Shop Floor Management User's Guide, Release 11i

Part No. A83717-07

Copyright © 1996, 2005, Oracle. All rights reserved.

Primary Author: Kevin Brown

The Programs (which include both the software and documentation) contain proprietary information; they are provided under a license agreement containing restrictions on use and disclosure and are also protected by copyright, patent, and other intellectual and industrial property laws. Reverse engineering, disassembly, or decompilation of the Programs, except to the extent required to obtain interoperability with other independently created software or as specified by law, is prohibited.

The information contained in this document is subject to change without notice. If you find any problems in the documentation, please report them to us in writing. This document is not warranted to be error-free. Except as may be expressly permitted in your license agreement for these Programs, no part of these Programs may be reproduced or transmitted in any form or by any means, electronic or mechanical, for any purpose.

If the Programs are delivered to the United States Government or anyone licensing or using the Programs on behalf of the United States Government, the following notice is applicable:

#### U.S. GOVERNMENT RIGHTS

Programs, software, databases, and related documentation and technical data delivered to U.S. Government customers are "commercial computer software" or "commercial technical data" pursuant to the applicable Federal Acquisition Regulation and agency-specific supplemental regulations. As such, use, duplication, disclosure, modification, and adaptation of the Programs, including documentation and technical data, shall be subject to the licensing restrictions set forth in the applicable Oracle license agreement, and, to the extent applicable, the additional rights set forth in FAR 52.227-19, Commercial Computer Software--Restricted Rights (June 1987). Oracle Corporation, 500 Oracle Parkway, Redwood City, CA 94065.

The Programs are not intended for use in any nuclear, aviation, mass transit, medical, or other inherently dangerous applications. It shall be the licensee's responsibility to take all appropriate fail-safe, backup, redundancy and other measures to ensure the safe use of such applications if the Programs are used for such purposes, and we disclaim liability for any damages caused by such use of the Programs.

The Programs may provide links to Web sites and access to content, products, and services from third parties. Oracle is not responsible for the availability of, or any content provided on, third-party Web sites. You bear all risks associated with the use of such content. If you choose to purchase any products or services from a third party, the relationship is directly between you and the third party. Oracle is not responsible for: (a) the quality of third-party products or services; or (b) fulfilling any of the terms of the agreement with the third party, including delivery of products or services and warranty obligations related to purchased products or services. Oracle is not responsible for any loss or damage of any sort that you may incur from dealing with any third party.

Oracle is a registered trademark of Oracle Corporation and/or its affiliates. Other names may be trademarks of their respective owners.

---

# Contents

## Send Us Your Comments

## Preface

### 1 Shop Floor Management Overview

Overview of Shop Floor Management . . . . .	1- 1
Shop Floor Management Flow . . . . .	1- 2
Multilevel Bills of Material . . . . .	1- 2
Network Routings . . . . .	1- 4
Enhanced Lot Functionality . . . . .	1- 5
Lot Attributes . . . . .	1- 6
Capturing Attributes During Lot Based Jobs Execution . . . . .	1- 6
Co-Products . . . . .	1- 6
Operation Yields . . . . .	1- 6
Integration with Oracle Applications . . . . .	1- 7
Component Picking . . . . .	1- 7
Completions into License Plate Numbers . . . . .	1- 8

### 2 Setting Up

Overview of Setting Up . . . . .	2- 1
Related Product Setup Steps . . . . .	2- 2
Setup Flowchart and Checklist . . . . .	2- 2
Setup Steps . . . . .	2- 4
Defining Parameters . . . . .	2- 7
Defining and Viewing Lot Sector Extensions . . . . .	2-11
Defining Standard Operation Details . . . . .	2-13
Attaching Files to Job Operations . . . . .	2-13
Setting Up Shop Floor Management Attributes . . . . .	2-14
Profile Options . . . . .	2-15
Concurrent Programs . . . . .	2-17

### 3 Network Routings

Overview of Network Routings . . . . .	3- 1
Creating a Network Routing . . . . .	3- 3

Modifying Network Routings . . . . .	3- 8
Importing Routings . . . . .	3- 9
Defining Alternate Resources for Standard Operations . . . . .	3-10
Defining Operation Yield Values on Routings . . . . .	3-11
Integration with Advanced Supply Chain Planning . . . . .	3-13
Integration with Outside Processing . . . . .	3-14

## 4 Lot Transactions

Overview of Lot Transactions . . . . .	4- 2
Creating a Lot Based Job . . . . .	4- 2
Overview of Lot Moves . . . . .	4- 8
Performing Lot Move Transactions . . . . .	4- 9
Operation Jumps . . . . .	4-12
Viewing Status and Resources . . . . .	4-13
Integration with Oracle Advanced Supply Chain Planning (ASCP) . . . . .	4-13
Capturing and Modifying Detailed Job Level Plan Recommendations . . . . .	4-14
Changing the Recommended Path of a Job to Any Other Intended Path for Future Operations . . . . .	4-14
Viewing Plan Resource Details . . . . .	4-15
Updating Plan Components . . . . .	4-16
Updating Plan Phantom Components . . . . .	4-18
Mass Refresh of Open Jobs . . . . .	4-19
Overview of Advanced Lot Transactions . . . . .	4-20
WIP Lot Transactions . . . . .	4-21
Creating WIP Lot Transactions . . . . .	4-22
Inventory Lot Transactions . . . . .	4-26
Creating Inventory Lot Transactions . . . . .	4-26
Creating Lots for New Sectors . . . . .	4-28
Kanban Replenishment on Lot Based Jobs . . . . .	4-30
Lot Based Job Reporting . . . . .	4-31
Lot Based Job Component Pick Release . . . . .	4-32
Pending Transactions Report . . . . .	4-32
Integration with Outside Processing . . . . .	4-33

## 5 Resource Scheduling Workbench

Overview of Resource Scheduling Workbench . . . . .	5- 1
Using the Resource Scheduling Workbench . . . . .	5- 2
Defining User Preferences . . . . .	5- 3
Job Operation Bars . . . . .	5- 4
Navigation . . . . .	5- 5
Viewing Property Windows . . . . .	5- 6
Capacity Exceptions . . . . .	5- 8
Showing Select Resources and Resource Load Versus Capacity Panes . . . . .	5- 8
Selecting a Resource . . . . .	5- 9
Adjusting Resource Capacity . . . . .	5-10

Rescheduling Jobs, Operations, and Resources in the Gantt Chart . . . . .	5-12
Rescheduling Start and End Dates . . . . .	5-13
Resource Transfer . . . . .	5-14
Transferring Work to an Instance . . . . .	5-15
Transferring Work Between Instances . . . . .	5-15
Transferring Work Between Alternate Resources . . . . .	5-15
Launching the HTML User Interface . . . . .	5-16
<b>6 Lot Genealogy</b>	
Overview of Lot Genealogy . . . . .	6- 1
Displaying Genealogy and Where-Used Views . . . . .	6- 2
<b>7 Co-Products</b>	
Overview of Co-Products . . . . .	7- 1
Defining Co-Products . . . . .	7- 1
Define Time Phased Split Percentages Window . . . . .	7- 3
Substitute Components Window . . . . .	7- 5
Component Details Window . . . . .	7- 5
<b>8 Costing in Oracle Shop Floor Management</b>	
Overview of Lot Based Job Costing . . . . .	8- 1
Cost Rollup for Network Routings . . . . .	8- 2
Standard Cost Update for Lot Based Jobs . . . . .	8- 2
Phantom Routings . . . . .	8- 2
Lot Based Jobs Transaction Costing . . . . .	8- 3
Move Transaction Costing . . . . .	8- 3
Estimated Scrap Accounting . . . . .	8- 3
Disabling Estimated Scrap and Operation Yield Accounting . . . . .	8- 6
Non Standard Expense Lot Based Jobs . . . . .	8- 6
WIP Lot Based Jobs Transaction Costing . . . . .	8- 7
Lot Split Transactions . . . . .	8- 7
Merge Lots . . . . .	8- 8
Bonus Lots . . . . .	8- 9
Update Quantity . . . . .	8-10
Update Routing and Update Assembly . . . . .	8-11
Lot Based Transaction are Integrated into Cost Manager . . . . .	8-11
Transaction Import through MES . . . . .	8-11
WIP Value Summary . . . . .	8-11
Reports . . . . .	8-12
<b>9 Closing Lot Based Jobs</b>	
Closing Lot Based Jobs . . . . .	9- 1
Unclosing Lot Based Jobs . . . . .	9- 5
Purging Lot Based Job Move Transactions . . . . .	9- 7

**A Windows and Navigator Paths**

Windows and Navigator Paths . . . . . A- 1

**Index**

---

# Send Us Your Comments

**Oracle Shop Floor Management User's Guide, Release 11i**

**Part No. A83717-07**

Oracle welcomes your comments and suggestions on the quality and usefulness of this publication. Your input is an important part of the information used for revision.

- Did you find any errors?
- Is the information clearly presented?
- Do you need more information? If so, where?
- Are the examples correct? Do you need more examples?
- What features did you like most about this manual?

If you find any errors or have any other suggestions for improvement, please indicate the title and part number of the documentation and the chapter, section, and page number (if available). You can send comments to us in the following ways:

- Electronic mail: [appsdoc\\_us@oracle.com](mailto:appsdoc_us@oracle.com)
- FAX: 650-506-7200 Attn: Oracle Supply Chain Management Documentation Manager
- Postal service:  
Oracle Supply Chain Management Documentation Manager  
Oracle Corporation  
500 Oracle Parkway  
Redwood Shores, CA 94065  
USA

If you would like a reply, please give your name, address, telephone number, and electronic mail address (optional).

If you have problems with the software, please contact your local Oracle Support Services.





---

# Preface

## Intended Audience

Welcome to Release 11i of the *Oracle Shop Floor Management User's Guide*.

This guide assumes you have a working knowledge of the following:

- The principles and customary practices of your business area.
- Oracle Shop Floor Management.

If you have never used Oracle Shop Floor Management, Oracle suggests you attend one or more of the Oracle Shop Floor Management training classes available through Oracle University.

- The Oracle Applications graphical user interface.

To learn more about the Oracle Applications graphical user interface, read the *Oracle Applications User's Guide*.

See Related Documents on page x for more Oracle Applications product information.

## TTY Access to Oracle Support Services

Oracle provides dedicated Text Telephone (TTY) access to Oracle Support Services within the United States of America 24 hours a day, seven days a week. For TTY support, call 800.446.2398.

## Documentation Accessibility

Our goal is to make Oracle products, services, and supporting documentation accessible, with good usability, to the disabled community. To that end, our documentation includes features that make information available to users of assistive technology. This documentation is available in HTML format, and contains markup to facilitate access by the disabled community. Accessibility standards will continue to evolve over time, and Oracle is actively engaged with other market-leading technology vendors to address technical obstacles so that our documentation can be accessible to all of our customers. For more information, visit the Oracle Accessibility Program Web site at <http://www.oracle.com/accessibility/>.

## Accessibility of Code Examples in Documentation

Screen readers may not always correctly read the code examples in this document. The conventions for writing code require that closing braces should appear on an otherwise empty line; however, some screen readers may not always read a line of text that consists solely of a bracket or brace.

## Accessibility of Links to External Web Sites in Documentation

This documentation may contain links to Web sites of other companies or organizations that Oracle does not own or control. Oracle neither evaluates nor makes any representations regarding the accessibility of these Web sites.

## Structure

- 1 Shop Floor Management Overview**
- 2 Setting Up**
- 3 Network Routings**
- 4 Lot Transactions**
- 5 Resource Scheduling Workbench**
- 6 Lot Genealogy**
- 7 Co-Products**
- 8 Costing in Oracle Shop Floor Management**

*The Oracle Cost Management User's Guide* is a prerequisite for understanding this chapter. Since lot based jobs use Standard Costing, sections specific to other costing methods may be skipped.

- 9 Closing Lot Based Jobs**
- A Windows and Navigator Paths**

## Related Documents

### **Oracle Bills Of Material User's Guide**

This guide describes how to create various bills of materials to maximize efficiency, improve quality and lower cost for the most sophisticated manufacturing environments. By detailing integrated product structures and processes, flexible product and process definition, and configuration management, this guide enables you to manage product details within and across multiple manufacturing sites.

### **Oracle Business Intelligence System Implementation Guide**

This guide provides information about implementing Oracle Business Intelligence (BIS) in your environment.

### **Oracle Cost Management User's Guide**

This guide describes how to use Oracle Cost Management in either a standard costing or average costing organization. Cost Management can be used to cost inventory, receiving, order entry, and work in process transactions. It can also be used to collect transaction costs for transfer to Oracle Projects. Cost Management supports multiple cost elements, multiple sub elements, and activity-based costing. It also provides comprehensive valuation and variance reporting.

### **Oracle General Ledger User's Guide**

This guide explains how to plan and define your chart of accounts, accounting period types and accounting calendar, functional currency, and set of books. It also describes how to define journal entry sources and categories so you can create journal entries for your general ledger. If you use multiple currencies, use this manual when you define additional rate types, and enter daily rates. This manual also includes complete information on implementing Budgetary Control.

### **Oracle Inventory User's Guide**

This guide describes how to define items and item information, perform receiving and inventory transactions, maintain cost control, plan items, perform cycle counting and physical inventories, and set up Oracle Inventory.

### **Oracle Purchasing User's Guide**

This guide describes how to create and approve purchasing documents, including requisitions, different types of purchase orders, quotations, RFQs, and receipts. This guide also describes how to manage your supply base through agreements, sourcing rules and approved supplier lists. In addition, this guide explains how you can automatically create purchasing documents based on business rules through integration with Oracle Workflow technology, which automates many of the key procurement processes.

### **Oracle Quality User's Guide**

This guide describes how Oracle Quality can be used to meet your quality data collection and analysis needs. This guide also explains how Oracle Quality interfaces with other Oracle Manufacturing applications to provide a closed loop quality control system.

### **Oracle Work in Process User's Guide**

This guide describes how Oracle Work in Process provides a complete production management system. Specifically this guide describes how discrete, repetitive, assemble-to-order, project, flow, and mixed manufacturing environments are supported.

## **Do Not Use Database Tools to Modify Oracle Applications Data**

Oracle **STRONGLY RECOMMENDS** that you never use SQL\*Plus, Oracle Data Browser, database triggers, or any other tool to modify Oracle Applications data unless otherwise instructed.

Oracle provides powerful tools you can use to create, store, change, retrieve, and maintain information in an Oracle database. But if you use Oracle tools such as SQL\*Plus to modify Oracle Applications data, you risk destroying the integrity of your data and you lose the ability to audit changes to your data.

Because Oracle Applications tables are interrelated, any change you make using an Oracle Applications form can update many tables at once. But when you modify Oracle Applications data using anything other than Oracle Applications, you may change a row in one table without making corresponding changes in related tables. If your tables get out of synchronization with each other, you risk retrieving erroneous information and you risk unpredictable results throughout Oracle Applications.

When you use Oracle Applications to modify your data, Oracle Applications automatically checks that your changes are valid. Oracle Applications also keeps track of who changes information. If you enter information into database tables using database tools, you may store invalid information. You also lose the ability to track who has changed your information because SQL\*Plus and other database tools do not keep a record of changes.



---

# Shop Floor Management Overview

This chapter covers the following topics:

- Overview of Shop Floor Management
- Shop Floor Management Flow
- Multilevel Bills of Material
- Network Routings
- Enhanced Lot Functionality
- Lot Attributes
- Co-Products
- Operation Yields
- Integration with Oracle Applications
- Component Picking
- Completions into License Plate Numbers

## Overview of Shop Floor Management

Oracle Shop Floor Management manages complex shop floor information and bridges the gap between Oracle Manufacturing and the shop floor by expanding the capabilities of Oracle's Manufacturing Applications. It enhances the core product by making integrated shop floor/MES information available at the enterprise level to combine manufacturing excellence with customer responsiveness. Oracle Shop Floor Management uses a single data repository to guarantee information consistency for manufacturing execution. You can create and release discrete jobs and lot based jobs in the same manufacturing organization. The major features include:

- MES/ERP(Enterprise Resource Planning) integration
- Network routings
- Complex lot transactions
- Lot Genealogy
- Operation yield costing
- Co-product definition

## Shop Floor Management Flow

The process flow begins when a primary component for the lot based job is created. When the lot is created and released, it moves through a series of operations to an inventory location, where it becomes an Inventory Lot. The Inventory Lot then moves into the next bill of material level, becoming a new WIP Lot. The new WIP lot moves through a series of operations, and is completed into inventory location for the next sector. This process is repeated through each sector until the last sector is complete.

The following graphic displays the Shop Floor Management flow described above.

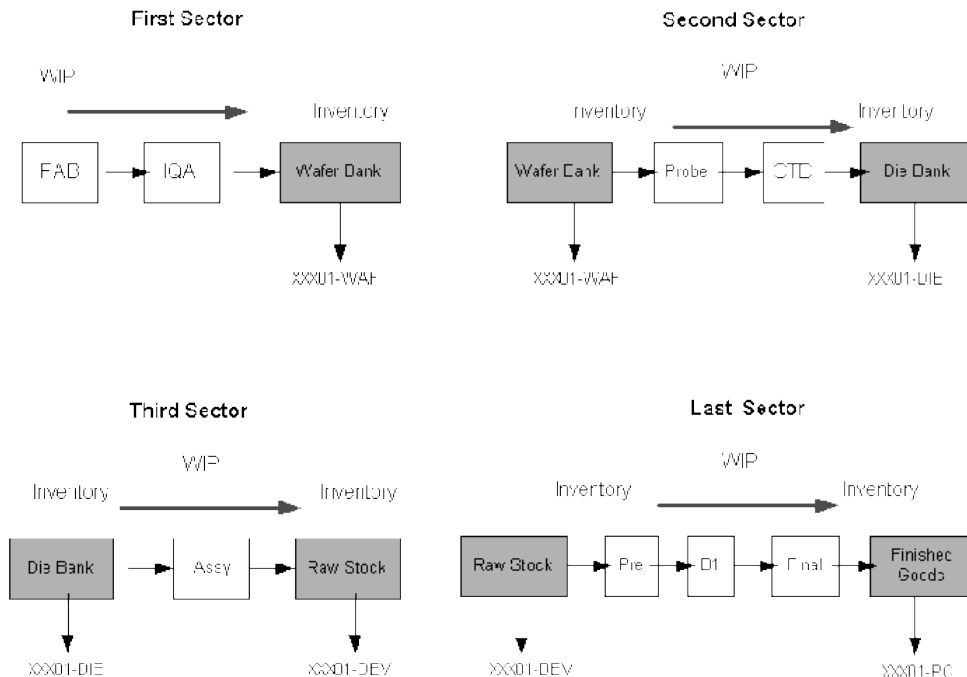

## Multilevel Bills of Material

The relationship between the items that represent the different forms the lot takes is stored as a multi-level bill of material. These items are called the primary assembly of that level of the bill. Each of these primary assembly items has its own routing.

A lot sector converts inventory lot components into a lot based job. When the job is completed it becomes an inventory lot for the next lot sector.

Lot based jobs support operation pull, push, and phantom supply types. Other supply types are not currently supported. Oracle Shop Floor Management does not currently support assembly pull supply type.

## Phantoms

Phantom assemblies are non-stocked assemblies used to group material. In discrete jobs, all routing operations are known. In lot based jobs, only the first operation is known. The difference in using a phantom supply type in lot based jobs is:

- Lot based jobs consider only the components and resource on the primary path of the routing if the Use Phantom Routing flag is set to Yes. Otherwise it considers all the components of the phantom in the primary and alternate path.

- Material requirements are exploded during job creation for the first operation, and during the subsequent move or jump operation.
- While performing update routing or update assembly transactions at the Queue intraoperation step, if you have phantom exploded components at the current operation—you must manually reverse the charges.

**Note:** Lot based jobs copy only the first operation, and do not explode the phantom assemblies at the last operation. Phantom material attached to the last operation is exploded when the job is moved to the last operation.

Before using phantom assemblies, the following parameters in Oracle Bills of Material need to be set:

- Use Phantom Routings—Indicates if the resource and overhead costs (including those for outside processing resources assigned to phantom routing operations) associated with the components are ignored, or charged to the job's assembly. Also determines whether only the components on the primary path, or all the components in the primary and alternate are exploded.
- Inherit Phantom Operation Sequence—This parameter is used by discrete and lot based jobs; the phantom routing operation sequence number is always inherited from the parent network operation sequence.

The following table explains the behavior of the phantom assemblies based on the BOM parameter set up for phantoms:

Scenario	Name of the Parameter	Setting	Behavior
Scenario 1	BOM: Use phantom routing	Yes	Material in primary path is exploded
Scenario 1	BOM: Inherit phantom operation sequence	Yes	The lot based job does not inherit phantom operation sequence from the phantom network but the operation sequence number is always inherited from the parent network operation sequence.
Scenario 2	BOM: Use phantom routing	No	Material in primary and alternate path is exploded. No resource requirement is created
Scenario 2	BOM: Inherit phantom operation sequence	No	The lot based job does not inherit phantom operation sequence from the phantom network but the operation sequence number is always inherited from the parent network operation sequence.
Scenario 3	BOM: Use phantom routing	Yes	Not Applicable
Scenario 3	BOM: Inherit phantom operation sequence	No	Not Applicable

**Note:** Oracle Shop Floor Management has some limitations while using the phantom supply type material:

- If the Bill of Material of the assembly calls for a phantom supply type material at the first operation, the Lot Creation window does not allow you to create the job and a warning message is displayed.
- Phantom material is always a non stocked item.
- You are not allowed to update the phantom supply type material using Material Transaction window.

## Network Routings

Oracle Shop Floor Management provides flexible routing ability for lot based jobs. This type of routing is used in businesses such as the semiconductor industry where



the paths that jobs take is not always known or understood at the time the job is created. Depending on the initial operation, subsequent operation paths are decided.

Flexible, or network routings enable you to define all possible operations paths that a job can take. This networked predefined path definition provides for dynamic flexible operation. Numerous possibilities are defined as part of a routing network, any one being selectable based on the outcome of the last operation within the job performed.

The routing network must have only one beginning and one ending operation. As the job goes through the production cycle, you build a history of operations that the WIP lot actually moves, selectable from the possibilities defined in the network.

A network of operations is available to model your shop floor, define possible rework points, or define a linear path. It consists of a series of nodes and paths which make up the routing network, and it is referenced by the Move Lot Based Jobs window to determine which operations a job can traverse.

You can also import network routings from 3P route builders into Oracle Shop Floor Management. Complete interface support is available that lets you import and modify network routings.

## Enhanced Lot Functionality

### Lot Transactions

WIP Lot Move transactions reference network routings and intra-operation steps. You can jump to other operations not defined on a network routing, and also put a job on hold at any operation.

The flow of a lot begins when a WIP Lot is created for the first sector's primary component and released. When it is completed, —it becomes an Inventory lot and can be issued to the next sector as the primary component. Oracle Shop Floor Management lot transactions include:

- Network routing moves
- Operation jumps
- Lot splitting
- Lot merging
- Lot renaming
- Bonus lots
- Translate lots
- Transfer lots
- Operation holds

### Lot Genealogy

The Lot Genealogy enables you to view the genealogy, or historical production information of a lot. It provides you with detailed lot information about the sectors the lot has moved through, and related lot transactions. It also enables you to view forward and backward direction or genealogy. View Genealogy to view historical informations in the Lot Genealogy window, see: *Displaying Genealogy and Where Used Views*, page 6- 2 .

## Lot Attributes

Lot attributes are key information elements that you can track with lot numbers. There are many attributes that you can track using Shop Floor Management. Lot attributes are entered as descriptive flex fields, and you can track attributes by item, and define attributes for validation requirements.

You can capture and track attributes of a lot based job during execution, from a lot start to completion. Attributes can be transferred from an inventory lot to a lot based job during the lot creation process, which would then be tracked through execution. When a job is completed, the job attributes are transferred to the resulting inventory lot.

## Capturing Attributes During Lot Based Jobs Execution

You can capture attributes of a Work in Process (WIP) lot during job execution. When a job is completed, the job attributes are transferred to the resulting inventory lot.

While executing WIP lot transactions such as a split or a merge, then the lot attributes from the parent or representative job transfer to the new lot. You can then update lot attributes on the resulting job if required. You can also capture or update lot attributes during a move transaction. Lot Genealogy displays details of lot attributes associated with a job. If an OSFM organization is set up for shop floor transactions, then you can also view details from the Materials Workbench.

Oracle Shop Floor Management does not currently support the following attribute functionality:

- Storing attribute data history after inventory lot transactions have been made
- Attribute based planning using Oracle Advanced Planning and Scheduling
- Capturing attributes using Kanban replenishment

## Co-Products

Oracle Shop Floor Management co-products extend standard Oracle Bills of Material definitions. You can use the Define Co-Products window to define an item as the primary component of several end items (for example, one ungraded die which produces several die grades). You define the primary end item and the expected distribution across all the end items. Upon entering this information in the Define Co-Products window, the bill of material of the end items are automatically created. You can also define co-product split percentages across different time periods.

## Operation Yields

Operation Yield costing enables you to include the cost of operation yield in the cost rollup of an assembly. You can also track the operation yield related variance by operation for lot based jobs. Oracle Shop Floor Management costing includes the following features:

- *Yield Definitions*—yields are defined at the operations level allowing cumulative and reverse cumulative yield calculations at every operation.
- *Costing Support*—cost rollup considers material, overhead and resource costs using operation yield at the operation rather than the shrinkage.

**Note:** Oracle Shop Floor Management only uses the standard costing method.

## Integration with Oracle Applications

Oracle Shop Floor Management expands the capabilities of Oracle's Manufacturing applications by making integrated shop floor information available at the enterprise level to combine manufacturing capabilities with customer responsiveness. This integration information allows scheduling and execution components to work together for job releases on the shop floor.

Oracle Shop Floor Management integrates with the following Oracle applications:

- Inventory
- Bills of Material
- Work in Process
- Cost Management
- Quality
- Warehouse Management
- Advanced Supply Chain Planning

If you enable Oracle Manufacturing Scheduling at the organization level, then you can use the Scheduler Workbench to schedule discrete jobs created in lot based organizations.

**Note:** Oracle Shop Floor Management does not integrate with Oracle Master Scheduling and MRP.

## Component Picking

You can perform component picking transactions for lot based jobs using the rules based system in Oracle Warehouse Management. The Component Pick Release window is used to select requirements and create move orders. It is a graphical workbench that displays fields applicable to the job or schedule type accessed. The features in component picking for lot based jobs include:

- Material source is based on Oracle Inventory allocation rules or Oracle Warehouse Management rules recommendations
- The status for lot based jobs picked must be Released or Complete – Charges Allowed
- Components are picked based on the network routing
- Move order quantities are calculated as assemblies per operation multiplied by the number of components, or:

The sum of all the quantities in each intra-operation step (Queue, Run, To Move, Reject and Scrap)

Multiplied by the component's quantity per assembly

### See Also

Overview of Component Picking, *Oracle Work In Process User's Guide*

Navigating on the Component Pick Release Window , *Oracle Work In Process User's Guide*

Using the Component Pick Release Window , *Oracle Work In Process User's Guide*

## **Completions into License Plate Numbers**

If Oracle Warehouse Management is installed, you can use License Plate Number functionality for tracking completions. License plate numbers are unique identifiers for tracking the contents of containers in receiving, work in process, inventory, shipping, and in- transit. You can perform assembly completions into license plate numbers. The container's genealogy provides content and transaction history for each license plate.

### **See Also**

Explaining LPN and Cross Docking Put Away, *Oracle Warehouse Management User's Guide*

Explaining License Plate Management, *Oracle Warehouse Management User's Guide*

---

## Setting Up

This chapter covers the following topics:

- Overview of Setting Up
- Related Product Setup Steps
- Setup Flowchart and Checklist
- Setup Steps
- Defining Parameters
- Defining and Viewing Lot Sector Extensions
- Defining Standard Operation Details
- Attaching Files to Job Operations
- Setting Up Shop Floor Management Attributes
- Profile Options
- Concurrent Programs

### Overview of Setting Up

This section contains an overview of the steps to complete setting Oracle Shop Floor Management. For instructions on how to complete each task, see the setup sections indicated in each step.

Setup involves several phases, including setting up other applications including Oracle Inventory, Oracle Bills of Material, and Oracle Work in Process. You may not need to perform some of the steps below if you've already performed a common-application setup.

### Set Up Oracle Applications Technology

The setup steps in this chapter describe how to implement Oracle Applications specific to Oracle Shop Floor Management. You need to complete several other setup steps, including:

- Performing system-wide setup tasks, such as configuring concurrent managers and printers
- Managing data security, which includes setting up responsibilities to allow access to a specific set of business data and transactions, and assigning individual users to one or more of these responsibilities

## Related Product Setup Steps

Oracle Shop Floor Management requires that Oracle Bills of Material, Oracle Cost Management, Oracle Inventory, and Oracle Work in Process are set up first.

### Oracle Inventory

Set up Oracle Inventory as described in Overview of Setting Up, *Oracle Inventory User's Guide*. Ensure that all the following steps have been completed:

- Create your organizations
- Define your organization parameters
- Define items and item costs
- Define your units of measure
- Define your subinventories
- Define your stock locators
- Define WIP supply types

### Oracle Bills of Material

Set up Oracle Bills of Material as described in Overview of Setting Up, *Oracle Bills of Material User's Guide*. Ensure that all the following steps have been completed:

- Define resources
- Define your departments
- Define your standard operations
- Create your workday calendar

### Oracle Cost Management

Set up Oracle Bills of Material as described in Overview of Setting Up, *Oracle Cost Management User's Guide*. Ensure that all the following steps have been completed:

- Define your cost types and cost elements
- Define your default WIP accounting classes for categories
- Define resources, material sub-elements, overheads, and overhead defaults

### Oracle Work in Process

Set up Oracle Bills of Material as described in Overview of Setting Up, *Oracle Work in Process User's Guide*. Ensure that all the following steps have been completed:

- Define WIP accounting class types
- Define WIP parameters

## Setup Flowchart and Checklist

Some of the steps outlined in this flowchart and setup checklist are:

- Required
- Required Step With Defaults

- Optional

Required Step With Defaults refers to setup functionality that comes with pre-seeded, default values in the database; however, you should review those defaults and decide whether to change them to suit your business needs. If you need to change them, you should perform that setup step. You need to perform optional steps only if you plan to use the related feature or complete certain business functions.

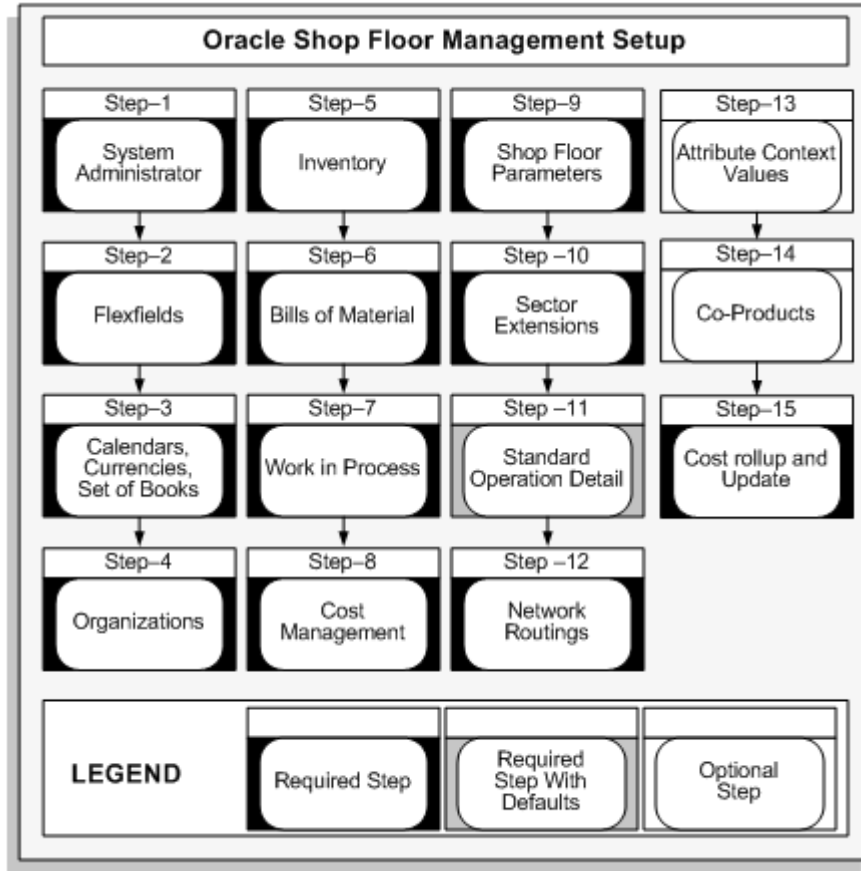

### Setup Checklist

The following table lists setup steps. After you log on to Oracle Applications, complete these required steps to implement Oracle Shop Floor Management.

### **Required Setup Steps**

<b>Step No.</b>	<b>Step</b>
Step 1	Set Up System Administrator
Step 2	Set Up Key Flexfields
Step 3	Set Up Calendars, Currencies, and Set of Books
Step 4	Set Up Organizations
Step 5	Set Up Oracle Inventory
Step 6	Set Up Oracle Bills of Material
Step 7	Set Up Oracle Work in Process
Step 8	Set Up Oracle Cost Management
Step 9	Define Oracle Shop Floor Management Parameters
Step 10	Define Sector Extensions
Step 11	Define Standard Operation Details
Step 12	Create Network Routings
Step 13	Define Attribute Context Values
Step 14	Define Co-Products
Step 15	Perform Cost Rollup and Cost Update for Assemblies

## **Setup Steps**

### **Step 1: Set Up System Administrator (Required)**

This step is performed while setting up different Oracle Applications products and involves the following tasks:

- Define responsibilities. See: *Oracle System Administration, Oracle Applications System Administrator's Guide*
- Set up printers (optional). See: *Setting Up Your Printers, Oracle Applications System Administrator's Guide*

### **Step 2: Set Up Key Flexfields (Required)**

You need to coordinate the flexfields of other applications you have set up before defining key flexfields here. See: *Oracle Applications Flexfield Guide*.



### **Step 3 (Required): Set Up Calendars, Currencies, and Set of Books**

This step is performed while setting up different Oracle Applications products. This step involves the following tasks:

- Set up calendars by defining period types, accounting calendar, transaction calendar, and workday calendar
- Define currencies and currency rates
- Assign your set of books to a responsibility
- Set up accounting code combinations

See: Oracle General Ledger User's Guide.

### **Step 4: Set Up Organizations**

You may not need to perform this step if you have already installed and set up Oracle inventory or performed a common-applications set up. This step involves the following tasks, for more information.

- Define organization lookups
- Define business groups
- Define organizations
- Define human resources organizations
- Define legal entities organizations
- Set up inventory organizations
- Define organization hierarchies
- Assign business groups and operating units to responsibilities

### **Step 5: Set Up Inventory**

This step includes defining Oracle Inventory components including:

- Define organizations
- Define items
- Define units of measure
- Define subinventories
- Define stock locators
- Define WIP supply types

**Note:** Organizations for Oracle Shop Floor Management should meet the following conditions: Standard Costing Method, Inventory Parameters Lot Uniqueness set to None, and WIP Parameter Default Lot Number Type set to Job Name.

### **Step 6: Set Up Oracle Bills of Material**

This step includes defining Oracle Bills of Material components including:

- Define BOM parameters
- Define resources

- Define department classes
- Define your departments
- Define your standard operations
- Create your workday calendar

**Note:** Lot based jobs support operation pull, push, and phantom supply types—other supply types are not currently supported.

### Step 7: Set Up Oracle Work in Process

This step includes defining Oracle Work in Process components including:

- Define WIP accounting classes

The WIP accounting class types used for Oracle Shop Floor Management are *Lot Based Standard Discrete* and *Expense Non-standard Lot Based*. See:

- Define WIP parameters

**Note:** Organizations for Oracle Shop Floor Management should set WIP Parameters Default Lot Number Type to Job Name, and Requisition Creation time to At Operation.

### Step 8: Set Up Oracle Cost Management

This step includes defining Oracle Cost Management components including:

- Define cost types
- Define your default WIP accounting classes for categories
- Define resources, material sub-elements, overheads, and overhead defaults
- Define costs for your item numbers

**Note:** Oracle Shop Floor Management only uses the standard costing method.

### Step 9: Define Oracle Shop Floor Management Parameters

This step defines default values for the transactions you are creating including:

- Designations for lots created
- Designations for jobs completed
- Define accounts for miscellaneous transactions
- Define default WIP Accounting class for lot based jobs and non-standard lot based jobs
- Define co-product supply for lot based jobs

See: Defining Parameters, page 2-7 , and WIP Accounting Classes, *Oracle Work in Process User's Guide*

### Step 10: Define Sector Extension Code

Sector extension codes are associated with assemblies and subinventories. These codes are appended to the job name when the assembly is completed to the subinventory.

**Note:** Subinventories are valid stocking points when they are associated with sector extension codes.

See: Defining and Viewing Lot Sector Extensions, page 2-11.

### **Step 11: Define Standard Operation Details**

This step defines the steps within an operation that are mandatory, and the location used for stocking points. See: Defining Standard Operation Details, page 2-13.

### **Step 12: Create Network Routings**

In this step you create a network of operations which include primary paths and alternate paths. You can define a separate routing for each item. See: Creating a Network Routing, *ERROR: linkend not in current document and TARGET\_BOOK\_TITLE missing*

### **Step 13: Define Attribute Context Values**

In this step you define context values for Shop Floor Management attributes. See: Setting Up Shop Floor Management Attributes, page 2-14

### **Step 14: Define Co-Products**

Co-product functionality gives you the ability to define an item as the primary component of several end items; the bill of material of the end items are automatically created. See: Defining Co-Products, page 7- 1

### **Step 15: Perform Cost Rollup and Cost Update for Assemblies**

Oracle Shop Floor Management provides operation yield costing that enables you to include operation yields in the cost rollup of an assembly. This step updates those calculations into the cost of your products. See: Bills and Cost Rollups, *Oracle Cost Management User's Guide*

## **Defining Parameters**

The Oracle Shop Floor Management parameters define operation movement and default values for the transactions you are creating.

### **To define Shop Floor Management parameters:**

1. Navigate to the Shop Floor Management Parameters window.
2. In the Lot Based Jobs region, set the value you want to use when lots are created and completed.
  - In the New Lot Separator field, the default value is a dash character (-) and can be changed to any value. When lots are created, split, or renamed—the resulting lot designation is the original lot number, followed by this value, followed by sequential numbering. See: WIP Lot Transactions, page 4-21, Inventory Lot Transactions, page 4-26

**Shop Floor Management Parameters (M4)**

**Lot Based Jobs**

New Lot Separator   Undo Last Move

Job Completion Separator   Honor Kanban Size

Default Accounting Class    Co Products Supply Default

Create Job Level BOM and Routing Copies

**Accounts**

Estimated Scrap Accounting

Miscellaneous Transaction Account

**Transactions**

Enable Inventory Lot Transactions

Jump from Queue

- In the Job Completion Separator field, the default value is a dash character (-) and can be changed to any value. When lots are completed the resulting lot designation is the original lot number, followed by this value, followed by the lot sector extension. See: Create Lot Move Transactions, page 4- 9 .

**Note:** Do not use the same character value in both the job completion separator, and in a segment of the job name. This creates an error in the resulting lot name.

After you save your work, you can change these values if the jobs have not been completed.

- The Undo Last Move indicator lets you undo the last move transaction. This indicator must be selected for the functionality to be defaulted on the Move Transaction window. See: Create Lot Move Transactions, page 4- 9
- Honor Kanban Size parameter is used to determine whether to create a lot based job quantity equal to kanban size when components are pushed from an inventory lot during kanban replenishment. If this indicator is not selected, then lot based jobs are created for the maximum number of assemblies which can be built using the selected component lot. If the indicator is selected, then the application will honor the kanban lot size.
- In the Co Products Supply Default field, the default value is empty, but can be selected. If the indicator is selected, then planning will take into consideration supply for the co-products.
- In the Default Accounting Class field, enter the accounting class to used as the default accounting class in the Lot Based Jobs window. If no other rules, like

getting the accounting class based on the item or subinventory association, return an accounting class then this default accounting class will be used.

- The Create Job Level BOM and Routing Copies field reflects the setting of the site level profile WSM: Create Job Level BOM and Routing Copies, which is applicable to all OSFM enabled organizations. See WSM: Create Job Level BOM and Routing Copies, page 2-17.
3. In the Accounts region, enter defaults for estimated scrap and miscellaneous transactions.
    - The Estimated Scrap Accounting field is used to disable scrap and operation yield calculations. The default value is Enabled, and the values are as follows:

*Enabled:* The application calculates Operation Yield Accounting and Estimated Scrap Absorption when creating transactions for lot based jobs. The Scrap Account field is required when defining a department in the Departments window.

*Disabled:* Operation Yield Accounting and Estimated Scrap Absorption are not calculated. The Scrap Account is not a required field in the Departments window; you can enter an account number at the time of the scrap transaction.
    - In the Miscellaneous Transactions Account field enter the account to be used when issuing or receiving material.
  4. In the Transaction region, set the value you want to use when the transactions are complete.
    - If you do not have Oracle Warehouse Management installed, select the Enable Inventory Lot Transactions indicator. This indicates that the Oracle Shop Floor Management Inventory Lot Transactions API is used for importing transactions into Oracle Applications.
    - If Oracle Warehouse Management (WMS) is installed, then Warehouse Management System users are encouraged to use WMS for Inventory Lot Transactions. You can run these transactions through the Warehouse Management System mobile (RF) user interface. You can view Inventory Lot Transactions performed in Warehouse Management in the Lot Genealogy window.
    - The Jump from Queue field is used to specify if material, resources and overhead charges of an operation are to be charged when you jump from queue of the operation. The default value is Charge Operation.

*Ignore Operation:* Ignores the operation, therefore material resources and overhead charges at the From operation are not charged.

*Charge Operation:* Materials, resources and overhead is charged at the From Operation.
  5. Save your work.

## Upgrading From a Previous Release

A new WSM: Create Job Level BOM and Routing Copies profile option with a value of Yes (Option 2) lets you create individual copies for each job by copying Bills of Materials (BOM) and network routings when a new lot based job is created. You can hold, modify, and view detailed information for each and every operation of the job. This is not possible using Option 1 since individual job copies are not created, and the

individual operation data is copied only when a you move to that operation. Selection of Option 1 or 2 is a site level decision. All organizations in that instance will have the same option. You should conduct extensive comparison, testing, and validation of Option 2 with your business processes since it is not possible to revert from Option 2 to Option 1. If you upgrade to 11i10, then you will remain on Option 1. You must apply a stand alone ARU to migrate to Option 2. ARU details are available on OracleMetaLink.

### To upgrade from a previous release:

1. Refer to the site level profile option WSM: Create Job Level BOM and Routing Copies. The value is set to No (Option 1). When you select any OSFM enabled organization, note that the field; Create Job level BOM and Routing Copies in the OSFM parameters window is set to No. Therefore, the site is running on Option 1 behavior. If you change the value of the parameter to Yes for Option 2 behavior, then the following window appears:

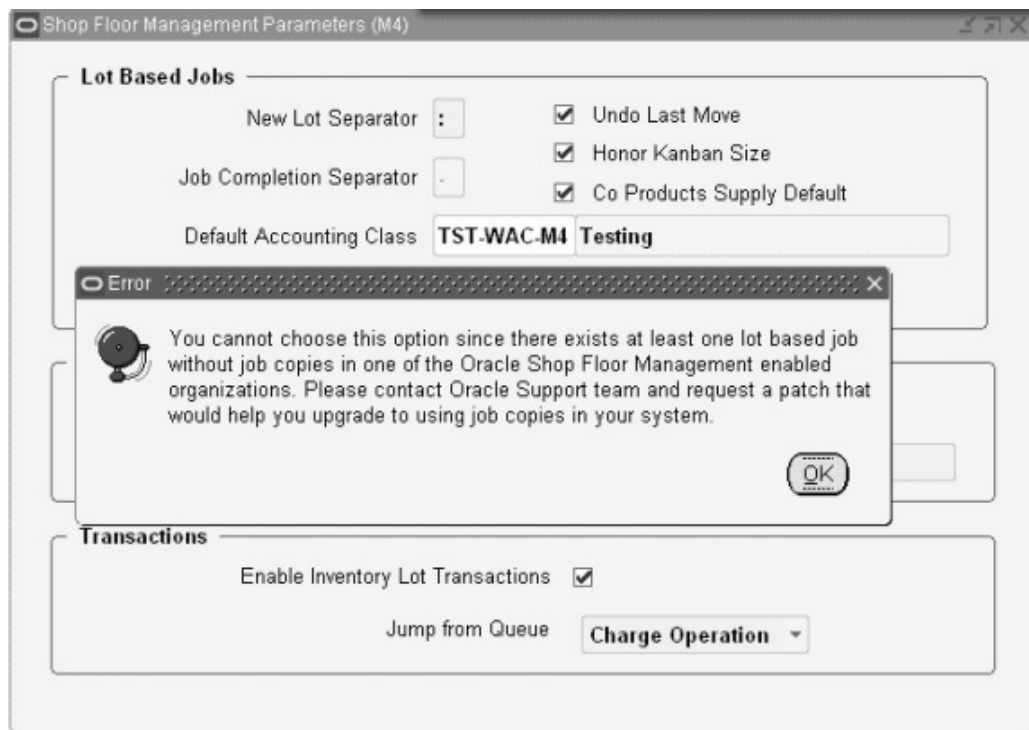

2. If you want to choose Option 2 behavior, then contact Oracle Support for access to an ARU that you access on Oracle MetaLink. After the application of this patch, the site will run using Option 2 behavior. The organization parameter value will be Yes, and the WSM: Create Job Level BOM and Routing Copies profile value is updated to Yes.

**Important:** After you apply the ARU, all organizations that are OSFM enabled in this site utilize Option 2 behavior, and you cannot revert to, or choose Option 1.

## New Installation Setup

You can set the WSM: Create Job Level BOM and Routing Copies profile option and parameter and utilize Option 2 behavior for new installations when no lot-based jobs with job-level copies exist.

### To set up parameters for a new installation:

1. Navigate to the site level profile option WSM: Create Job Level BOM and Routing Copies and note that the default value is No.
2. Navigate to the Parameters window and for the first organization being OSFM enabled, set the Create Job Level BOM and Routing Copies to Yes.
3. Save your work. Your site is now using OSFM Option 2 behavior.
4. Navigate back to the WSM: Create Job Level BOM and Routing Copies profile option and verify that the value is now Yes.

**Important:** All organizations that are OSFM enabled in this site utilize Option 2 behavior, and you cannot revert to, or choose Option 1.

If you choose Option 1 after you upgrade to Option 2, then an error message appears. You cannot choose this option if lot-based jobs with job-level copies exist.

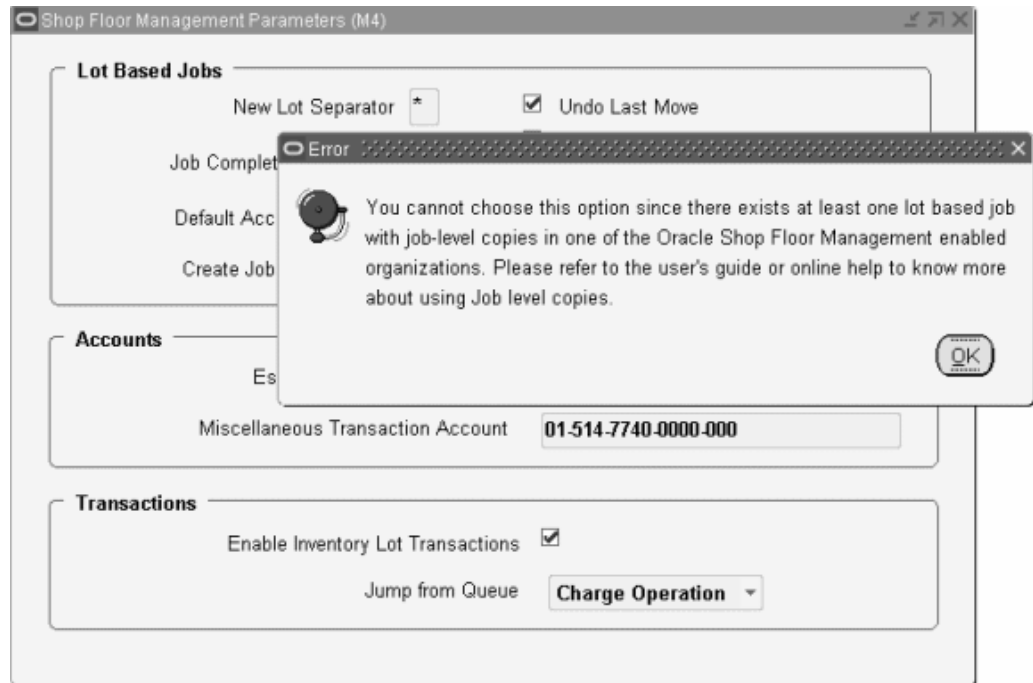

## Defining and Viewing Lot Sector Extensions

A different item number is associated with the lot for each stage on the shop floor. The relationship between the item numbers for these different stages is stored in a multi-level bill of material. A lot sector is a level of the bill that converts Inventory lot components into a lot based job. When the job is completed it becomes an Inventory lot for the next lot sector.

**Note:** The profile option WSM: Complete Job Sector Lot Extension Level defines the extension appended to the lot sector. See: Profile Options, page 2-15

## To define and view the Lot sector extension codes:

1. Navigate to the Sector Extensions and Item/Subinventory Association window.

The Find Sector Extension window displays. You can query lot sector extensions by subinventory name, item name, or both.

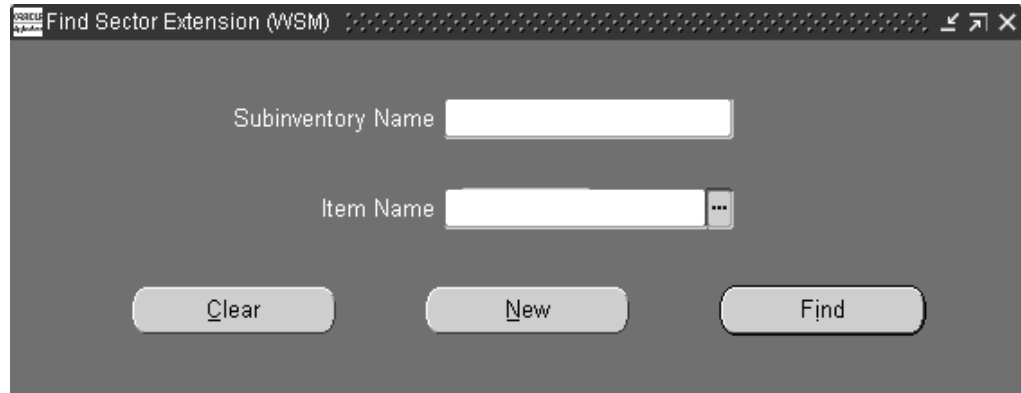

Find Sector Extension (WSM)

Subinventory Name

Item Name

Clear New Find

2. If you are searching for an existing lot sector extension, enter search criteria and choose Find. Choose New to create a new record.

The Sector Extension and Item/Subinventory window displays.

3. Enter a unique value in the Sector Extension Code field, and a description.

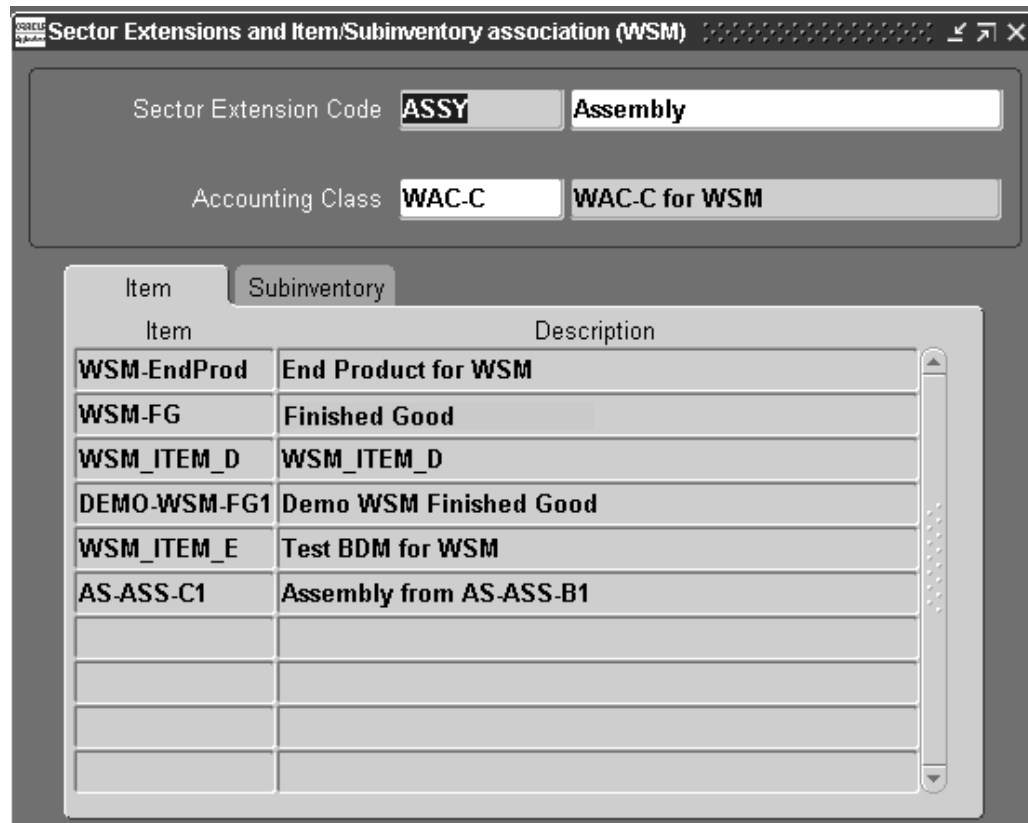

Sector Extensions and Item/Subinventory association (WSM)

Sector Extension Code

Accounting Class

Item Subinventory

Item	Description
WSM-EndProd	End Product for WSM
WSM-FG	Finished Good
WSM_ITEM_D	WSM_ITEM_D
DEMO-WSM-FG1	Demo WSM Finished Good
WSM_ITEM_E	Test BDM for WSM
AS-ASS-C1	Assembly from AS-ASS-B1

4. Select an accounting class from the Accounting Class Code list of values window.



5. In the Item tab, select the item numbers to assign to this lot sector.
6. In the Subinventory tab, select the subinventory location associated with this sector extension. See: *Assigning Items to a Subinventory*, *Oracle Inventory User's Guide*
7. Save your work.

**Note:** Subinventories are valid stocking points when they are associated with sector extension codes. An item or subinventory is associated with only one sector extension.

## Defining Standard Operation Details

Operation code information for standard operations is defined on the Standard Operation Details window. This window sets the intraoperation steps that are mandatory and subinventory location used as the stocking point.

### To define standard operation details:

1. Navigate to the Standard Operation Details window.
2. Select an operation code in the Standard Operation field.

3. In the Mandatory Intraoperation Steps region, check the steps that you want as mandatory within an operation. See: *Intraoperation Steps*, *Oracle Work in Process User's Guide*.
4. In the Stocking Point region—Subinventory field, select the default location that completed material from this operation is to be placed.  
If this subinventory is locator controlled, the Stock Locator field is enabled.
5. Save your work.

## Attaching Files to Job Operations

You can attach explanatory files, such as text, images, spreadsheets and video files to lot-based job operations. If you define the attachment to the operation in the Standard Operations window, then it is linked to the routing when created in the Routing Network window. You can delete and add new files as required.

When a job is created in the Lot Based Job window, the attachment of the first operation is automatically copied from the network routing. Attachments are also copied from the network routing during lot move transactions, splitting lots, and updating routings or

assemblies. If you are performing an operation jump in a network routing, attachments are copied from the operation as defined in the Standard Operations window.

**Note:** Until Patchset H, the first and last operation is copied into the job. Going forward, only the first operation is copied into a Lot Based Job.

## See Also

Attachments, *Oracle Applications User's Guide*.

Attaching Files to Jobs, Schedule, and Operations, *Oracle Work in Process User's Guide*.

## Setting Up Shop Floor Management Attributes

Lot attributes are key information elements that you can track with lot numbers. There are many attributes that you can track using Shop Floor Management. Lot attributes are entered as descriptive flex fields, and you can track attributes by item, and define attributes for validation requirements.

See: Set Up Item Attributes, *Oracle Warehouse Management User's Guide*.

Lot and Serial Attribute Setup, *Oracle Warehouse Management Implementation Guide*.

### To define lot attribute context value:

1. Navigate to the Descriptive Flexfield Segments window.
2. Select the flashlight icon from the tool bar, and then select the Oracle Inventory Application with the Title, Lot Attributes.
3. Unfreeze the Flexfield Definition by deselecting the Freeze Flexfield Definition indicator.
4. In the Context Field Values region, select a row, then click the New icon. A blank row is added for you to create an attribute group.
5. Enter the attribute group name in the Code field.
6. Optionally, enter a Description for this attribute group.
7. Select Segments to add attributes to the attribute group you just created.
8. Enter a Number to sequence the data.
9. Define the Name of the specific attribute. The Window Prompt defaults to this name.
10. Select a Column value.
11. Select a Value Set, or optionally, choose New to create a new one.
12. If the Displayed indicator is selected, then this attribute appears for you when defining data for an asset within the Asset Group (for example, CARS) associated with the attribute group (for example, NAMEPLATE) that this attribute (for example, Make) resides in.
13. Optionally, select the Enabled indicator to enable the attribute for availability when defining assets.
14. Save your work, and return to the Descriptive Flexfield Segments window.

15. Select the Freeze Flexfield Definition indicator. Failure to do this prevents you from querying the segments from the Attribute window.
16. Save your work.  
You can capture attributes of a Work in Process (WIP) lot during job execution. See *Capturing Attributes*, page 4-33.
17. Choose Submit to run the report.

## Profile Options

During your implementation, you set a value for the profile option used in Oracle Shop Floor Management to specify how the application controls access and processes data.

Generally, your system administrator sets up and updates profile option values. The *Oracle Applications System Administration User's Guide* contains more information on profile options.

The table uses the following values to describe profile option controls for columns *User*, *System Admin User*, *System Admin Resp*, *System Admin App*, and *System Admin Site*:

- **Yes:** You can update the profile option.
- **View Only:** You can view the profile option value in the Profiles window, but you cannot change it.
- **No:** You cannot view or change the profile option value.

The table displays the recommended settings for these profile options.

Profile Option	User	System Admin. User	System Admin. Resp.	System Admin. App.	System Admin. Site	Required	Default Value
WSM: Allow Operation Jumps	View Only	Yes	Yes	Yes	Yes	Optional	Yes
WSM: Create Job Level BOM and Routing Copies	Yes	Yes	Yes	Yes	Yes	Optional	No
WSM: Complete Job Sector Lot Extension Level	View Only	View Only	View Only	View Only	Yes	Optional	
WSM: Maximum Number of Import Lot Job Workers	View Only	View Only	View Only	View Only	Yes	Optional	10
WSM: Maximum Number of Rows Processed By a Lot Based Job Worker as a Batch	Yes	Yes	Yes	Yes	Yes	Optional	1000
TP: WSM: Open Interface Successful transactions archive days	Yes	Yes	Yes	Yes	Yes	Optional	365

### WSM: Allow Operation Jumps

Controls whether operation jumps can be performed in the Move Transactions window. User Values are:

- *Yes*: Enables you to skip operations or jump to any standard operation defined in the network routing
- *No*: You are not allowed to skip operations or jump other operations in the network routing

### **WSM: Create Job Level BOM and Routing Copies**

A site level profile option WSM: Create Job Level BOM and Routing Copies determines the behavior of OSFM.

If this is NO (Option1), then OSFM will not allow operation level details of Oracle APS (or third-party planning system) plans for lot based jobs.

If this is YES (Option 2) then OSFM has visibility into the detailed planning for lot based jobs as performed by Oracle APS (or third-party planning system).

The default value of No for this profile option implies Option 1 behavior.

### **WSM: Complete Job Sector Lot Extension Level**

Controls whether to use the Item level or Subinventory level sector extension when a job is completed. See: Defining and Viewing Lot Sector Extensions, page 2-11 User Values are Item or Subinventory:

- If a sector lot extension is defined at both Item and Subinventory level, and this profile is set to Subinventory, the job appends the sector lot extension from the subinventory.
- If the profile is set to Item or is not defined, the job appends the sector lot extension from the item level.

### **WSM: Maximum Number of Import Lot Job Workers**

Controls the maximum number of workers that can be launched in parallel to process the Lot Based Job Import records.

### **WSM: Maximum Number of Rows Processed by a Lot Based Job Worker as a Batch**

Controls the maximum number of rows in the Lot Based Job Import interface that can be processed as a batch by each worker launched to import lot based jobs.

### **WSM: Open Interface Successful Transactions Archive Days**

Controls when the Move processor deletes the successfully processed lot move interface rows. User Value defaults to 365 Days. User Values are entered in Days.

## **Concurrent Programs**

### **Upgrade To Use Lot Based Copy Routing**

Run the concurrent program executable *Upgrade To Use Lot Based Copy Routing* to upgrade to the new Shop Floor Management behavior (Option 2). You cannot revert to the old behavior (Option 1) once you upgrade.

This request will create copies for all Released, Unreleased, On Hold, Complete and Closed Jobs in all OSFM enabled organizations. If no records are created for any job in any of its copy tables, then it indicates success.

This request generates a list of jobs for which copies are created.

If copies of all the affected jobs are successfully created, then this program exits successfully, or it will rollback all copies created and display a warning message asking you to run the program again.



---

## Network Routings

This chapter covers the following topics:

- Overview of Network Routings
- Creating a Network Routing
- Modifying Network Routings
- Importing Routings
- Defining Alternate Resources for Standard Operations
- Defining Operation Yield Values on Routings
- Integration with Advanced Supply Chain Planning
- Integration with Outside Processing

### Overview of Network Routings

Network routings in Oracle Shop Floor Management, comprise all possible operations defined for manufacturing a particular assembly. While discrete jobs use standard routings, lot based jobs use network routings. The primary feature of network routings is, based on the results of an operation, to define different paths for the next operation. However, there must be a unique start and last operation defined in the network. When this information is captured, a network of operations is available for processing a lot based job on the shop floor.

You define two major aspects to create this functionality. First, all the possible allowable operations are defined in the Oracle Shop Floor Management Routings window as shown in the following illustration. Operation yield information for costing updates is also defined in the Operation Yield tab of this window.

**Operations**

Main Date Effectivity WIP Operation Yield ECO Description

Referenced

Seq	Code		Effectivity Date	Effectivity Time	Disable Date	Disable Time
10	VB20	<input checked="" type="checkbox"/>	17-MAR-2003	13:16:22	28-MAR-2003	11:36:44
20	OSP	<input checked="" type="checkbox"/>	11-MAR-2003	13:57:02		
30	VB20	<input checked="" type="checkbox"/>	11-MAR-2003	13:57:12		
40	VB30	<input checked="" type="checkbox"/>	11-MAR-2003	13:57:20		
50	VB40	<input checked="" type="checkbox"/>	11-MAR-2003	13:57:29		

Routing Details Routing Network Operation Resources

Next, the network operations are defined in the Routing Network window. Here the primary and alternate paths are outlined, and the percentage each is likely to be used. This percentage is used by Advanced Supply Chain Planning.

The combination of definitions provides for dynamic, flexible operation of a job. There are numerous possibilities in executing a routing and any one of these can be based on the outcome of the last operation performed. However, there must be a unique starting operation and a unique ending operation in the entire network.

As seen in this illustration, the first example shows the Network—that is, the entire network of the routing and all operations that the WIP Lot can use.



### Network Relationships

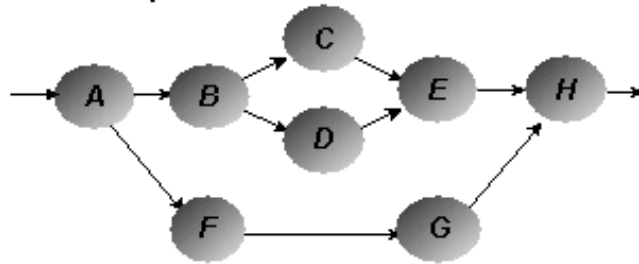

### Primary Path

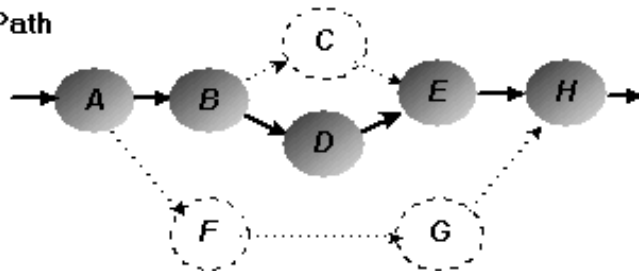

### Actual Completion Path

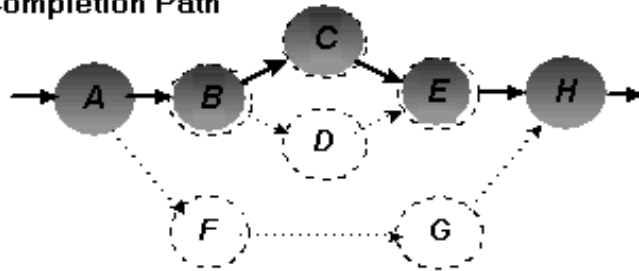

The next example—Primary Path—shows the main path that a job is most likely to follow.

And the third example—Actual Completion Path—shows the real route a particular job moved. This path could be the primary path or any of the other valid paths defined in the network. In the illustration, the job deviates from the primary path after operation B, and moves to operation C instead of D.

Once a complete network routing is defined for a sector, a WIP lot begins at the first operation of the network. As the job completes the first step, you select the next operation in the network. This can be the operation on the primary path, or any valid alternate paths. The process continues until the job reaches the last step when the job is completed.

## Creating a Network Routing

The network routing defines different paths for the next operation. Oracle Shop Floor Management enables you to use both standard and non-standard operations in network routings, and supports repeating operations—standard and non-standard.

## To create a network routing:

1. Navigate to the Routings window in the Oracle Shop Floor Management menu and enter information to define this item's routing.

This includes item number, alternate routing designator, revision, operation sequence, operation code, department, effective date, effective time, disabled date and disabled time. See: *Creating a Routing, Oracle Bills of Material User's Guide*.

**Note:** When jobs are moved through network routing or WIP lot transactions are performed, Oracle Shop Floor Management considers an operation effective if the job's routing revision is greater than or equal to the operations effective date and less than or equal to its disable date if defined. In addition, a component is considered as effective if its effective date is less than or equal to the job's BOM revision date.

The operation sequence numbers entered for each operation in this window do not signify the order of the particular operation in Oracle Shop Floor Management. The actual operation sequencing is built as you choose the operations based on the network path.

Seq	Code	Effectivity Date	Effectivity Time	Disable Date	Disable Time
10	VB20	17-MAR-2003	13:16:22	28-MAR-2003	11:39:22
20	0SP	11-MAR-2003	13:57:02		
30	VB20	11-MAR-2003	13:57:12		
40	VB30	11-MAR-2003	13:57:20		
50	VB40	11-MAR-2003	13:57:29		

2. Choose Routing Details to enter completion subinventory and locator information, or to view a common routing.

The completion subinventory defaults from the stocking point of the last operation. See: *Completion Subinventory and Locator Fields, Oracle Bills of Material User's Guide*.

You can unreference a standard operation at this time. This lets you enter more resource information for that particular operation. You can also enter any alternate resources or additional resources by unreferencing a standard operation.

3. Save your work.

4. Choose Routing Network.

The Routing Network window displays the assembly item number and alternate number.

**Note:** If you do not save your record in the Routings window, then you cannot enter data on the Routing Network window.

From Seq	Code	From Op Description	From Dept	To Seq	Code	To Op Description	To Dept	Primary or Alternate Path	Planning %
10	PB10	Load Probe Machine	Probe	20	PB20	Probe Machine	Probe	PRIMARY	90
10	PB10	Load Probe Machine	Probe	80	DG01	DG osp op 1	dg_osp_d1	ALTERNATE	10
20	PB20	Probe Machine	Probe	30	PB30	Unload Probe Machi	Probe	PRIMARY	100
30	PB30	Unload Probe Machin	Probe	40	PB40	Review Probe Result	Probe	PRIMARY	100
40	PB40	Review Probe Results	Probe	50	PB45	Re-Probe	Probe	ALTERNATE	20
40	PB40	Review Probe Results	Probe	60	PB50	Disposition Probe	Probe	PRIMARY	80
50	PB45	Re-Probe	Probe	70			Probe	ALTERNATE	100
70			Probe	60	PB50	Disposition Probe	Probe	ALTERNATE	100
80	DG01	DG osp op 1	dg_osp_d1	60	PB50	Disposition Probe	Probe	ALTERNATE	100

5. Select or enter operation sequence information.

For standard operations, select the operation sequence code in the From Sequence field—operation code, description, and department automatically display.

For non-standard operations, enter the operation sequence code in the From Sequence field—the department automatically displays.

6. Select the operation sequence code in the To Sequence field—operation code, description, and department automatically display.

7. Select either primary or alternate path for this operation.

Primary indicates that this is a routing path used most often, while alternate indicates that it is used as a backup. This window validates that the primary path is a complete chain of operations from start to end.

You can have only one unique primary path. Loops are not permitted in the primary path but are in the alternate paths.

8. In the Planning % field, enter the percentage that this path is used.

Percentages for all the paths—originating from any node in the routing network, or ending on any node—must total 100 percent.

9. Repeat Steps 5 through 7 for all the operations in the routing network.

Only one first operation and one last operation are allowed in the routing network.

10. Save your work.

**To define an operation effectivity:**

Navigate to the Routings window.

1. Enter information to define this item routing.

2. Select the Date Effectivity tabbed region.
3. For the first operation sequence, select a Disable Date and Disable Time

**Note:** The effectivity of an operation in a routing is determined by the job routing revision date, rather than the transaction date.

The screenshot shows the 'Routings (VBO)' window with the following details:

- Item: VB60001, Description: Processed Wafer, UOM: Ea
- Revision: A, Date: 28-MAR-2003
- Display: Future and Current, Implemented Only: checked

The 'Date Effectivity' tab is active, showing the following table:

Seq	Code	Effectivity Date	Effectivity Time	Disable Date	Disable Time
10	VB20	17-MAR-2003	13:16:22	28-MAR-2003	11:39:22
20	0SP	11-MAR-2003	13:57:02		
30	VB20	11-MAR-2003	13:57:12		
40	VB30	11-MAR-2003	13:57:20		
50	VB40	11-MAR-2003	13:57:29		

Buttons at the bottom: Routing Details, Routing Network, Operation Resources.

4. Save the change before enabling the new operation.
5. Enter the Effective Date for the new operation.
6. Save your work.
7. Choose Operation Resource to view the details on resource and resource usage at this operation.

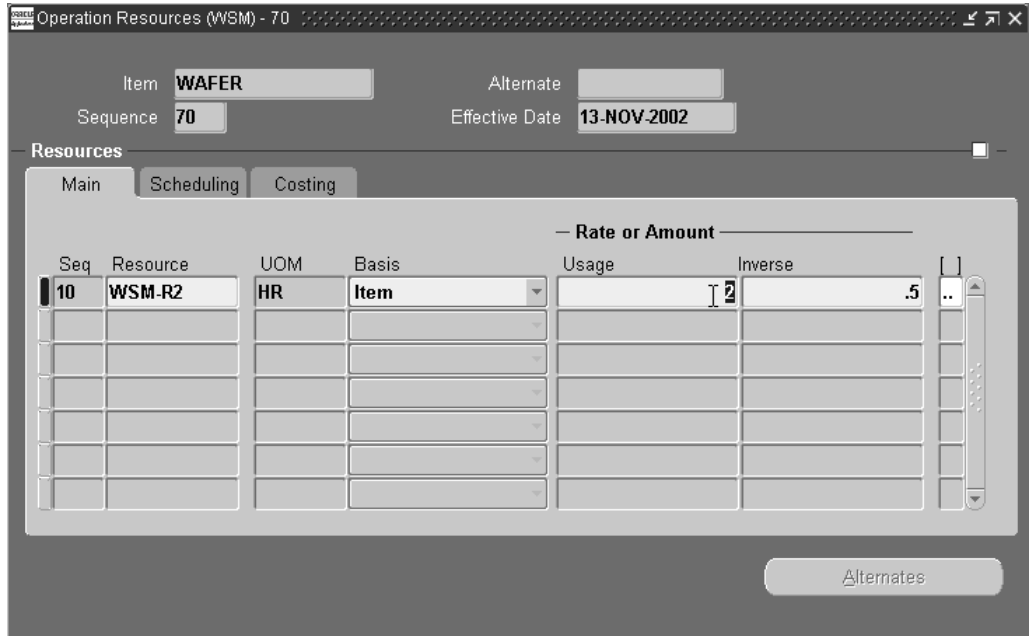

8. Navigate to the Bills of Material window.
9. Select values in the From and To Effectivity Date fields for the first component.
10. Select values in the From and To Effectivity Date fields for your new component.
11. Save your work.

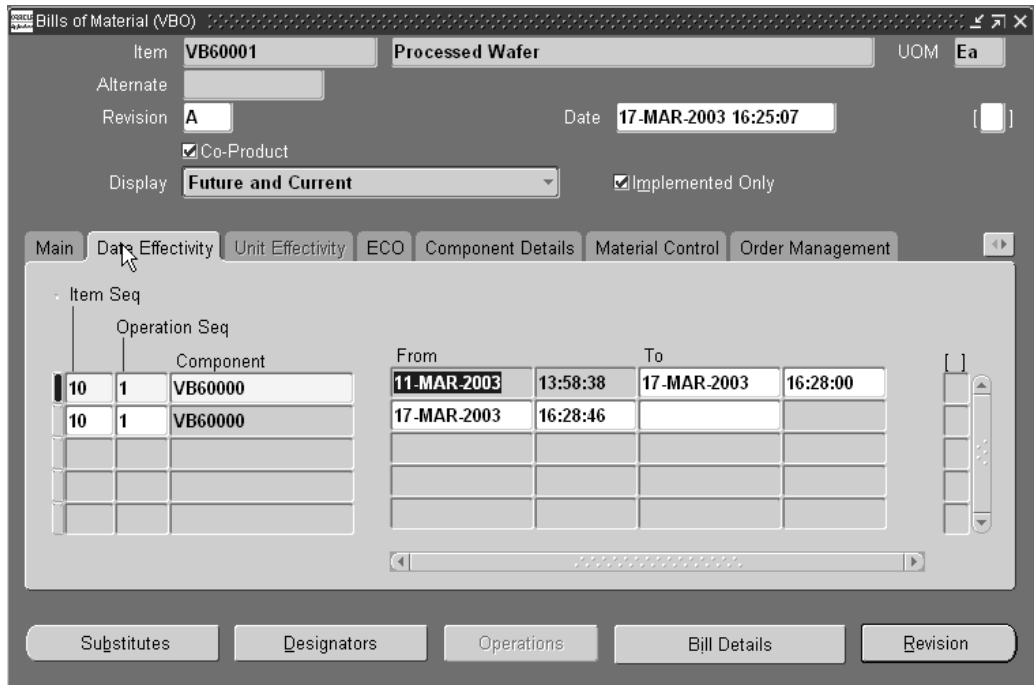

12. Navigate to Lot Based Jobs window.

Operation Effectivity and the Component Effectivity defined earlier can be seen when you create a lot based job using the revision date for the routing or Bill of Material.

If the system date is greater than the job start date, then the system date is used for the routing revision date and the BOM revision date

You can change this system default date to any date to implement the operation or component effectivity.

Lot Based Jobs (VBO)

Job: 37573      Type: Standard

Assembly: VB60001      Processed Wafer

Class: STDLBJ      UOM: Ea

Status: Released       Firm

**Quantities**

Start: 11

MRP Net: 11

**Dates**

Start: 13-MAR-2003 10:21:00

Completion: 13-MAR-2003 10:21:00

Bill    Routing    Job History    Schedule Group, Project    Planning, Scheduling    More

Reference: \_\_\_\_\_

Alternate: \_\_\_\_\_

Revision: A      Revision Date: 13-MAR-2003 10:21:00

Supply Type: Based on Bill

Operations    Components

13. Save your work.

**Note:** Lot based jobs explode the material and resource requirement for the first operation only. At the time of job creation, the BOM revision and routing revision is copied into the job and the material.

## Modifying Network Routings

You can modify network routings in several different ways:

### To add or modify a network routing:

1. Navigate to the Routings window in the Oracle Shop Floor Management menu.
2. If you are adding a new operation, enter this operation in the Main tab of the Routings window.
3. Save your work.
4. Choose Routing Network.

The Routing Network window displays with the assembly item number and network.

5. Modify networks per your new requirements. Paths that are not required can be deleted— with the exception of the first or last operation of a network routing.
6. Save your work.

### To delete network routing paths:

Navigate to the Routing Network window.

1. Select the routing path you want to delete, and choose delete from the Edit menu.

Delete Standard operations from a routing in the Standard Operations window. See: *Operations, Oracle Bills of Materials User's Guide*.

You must enter a delete group before deleting operations from a network routing. In addition, if an operation from a network routing is being made ineffective or deleted, then OSFM checks for current jobs at that operation and displays a caution message if appropriate.

2. Save your work.

**Note:** You are not allowed to delete the first or last operation of a network routing, and the last operation of a network cannot be changed. Therefore, it is recommended that you model the last operation as a dummy operation to leverage and maximize the power of network routings.

If you set the WSM: Create Job Level BOM and Routing Copies profile option to No (Option 1), then modification to a network routing affects all open jobs. If you set the WSM: Create Job Level BOM and Routing Copies profile option to Yes (Option 2), then modifications to a network routing can be done at the job level. See: *Mass Refresh of Open Jobs*, page 4-19.

## Importing Routings

### Importing Operations in a Network Routing

The Routing Open Interface program enables you to import routing information. Imported routing details include routing revision, operation, instruction, and resource information. See: *Importing Bills and Routings, Oracle Bills of Material User's Guide*.

### Importing Network Routings

You can import complete network routings and the primary and alternate network path definitions using Open Interface Tables. The BOM Business Objects API performs the necessary validations for network paths. You can also update the existing operations with the routing effectivity date changes, or implement time phased yield values for different operations of a routing. See: *Bills of Material Business Object Interface, Oracle Manufacturing APIs and Open Interfaces Manual*.

### See Also

Primary and Alternate Routings, *Oracle Bills of Material User's Guide*

Routing Revisions, *Oracle Bills of Material User's Guide*

Operations, *Oracle Bills of Material User's Guide*

## Defining Alternate Resources for Standard Operations

You can define alternate resources while defining standard operations. Standard operations contain the alternate resources. Alternate resources connect to primary resources using a substitute group number. When an operation is referenced in the network routing, the application copies the alternate resources and primary resources to the routing operation. Oracle Advanced Planning also uses this data while planning for operations.

You can also assign substitute group numbers and replacement group numbers. See: Assigning Operation Resources, *Oracle Bills of Material User's Guide*.

### To define alternate resources for standard operations:

1. Navigate to the Standard Operations window.
2. Select an operation and choose Operation Resources. The Resources window appears.

Seq	Resource	UOM	Basis	Usage	Inverse
10	TST_LBR	HR	Item	.01	100

Alternates

3. Choose Alternates. The Operation Alternate Resources window appears.
4. Select the resource Name.  
You can add any resource that is assigned to the department of the operation you have selected. You can also add any multi- departmental resource.
5. Select a resource Basis. The options are as follows:  
**Item:** Charge and schedule the resource on an item-by-item basis. Select Item when resource times and costs are dependent on the job or schedule quantity, such as when charging per unit labor costs.



**Lot:** Charge and schedule the resource on a one per job or schedule basis. Select Lot when resource times and costs are independent of quantity, such as when setting up a machine to run an entire job.

You cannot update the resource basis if you have charged against the resource.

6. Enter the Usage Rate or Amount Value or Inverse.

**Value:** Enter a Value if you know how much of the resource is consumed at the operation (per item or per lot) given the resource UOM. For example, if your manufacturing process consumes a mold (resource UOM=EA) for every 5 items produced, enter a Value of 0.2 (1/5). When you enter the Value of 0.2, the Inverse is automatically calculated as 5. In other words, producing one unit consumes 0.2 of the mold.

**Inverse:** Enter an inverse amount if you know the number of units a resource can process given the resource UOM. For example, if you can process 10 units on a lathe (resource UOM = HR) in an hour, enter an inverse amount of 10. When you enter the inverse amount of 10, the value is automatically calculated as 0.1 (1/10). In other words, each unit takes 0.1 hours to process.

You cannot enter a quantity less than zero for resources with time-based units of measure. When you enter the usage rate or amount, the inverse usage rate or amount is automatically supplied.

7. Save your work.

## Defining Operation Yield Values on Routings

### To define yield values on a routing:

1. Navigate to the Routings window and enter the item number.

This includes item number, alternate item number, revision, display option, operation sequence, operation code, department, and date ranges, see: *Creating a Routing, Oracle Bills of Material User's Guide*.

Item: CM71000    Description: Processed Wafer    UOM: Ea

Alternate:     Capable To Promise

Revision: 0    Date: 14-MAY-2001

Display: Future and Current     Implemented Only

**Operations**

Main    WIP    **Operation Yield**    ECO    Description

Seq	Code	Yield	CUM Yield	Reverse CUM Yield	Net Planning %	Include In Rollup
10	FB10	.9	.9	.4212	100	<input checked="" type="checkbox"/>
20	FB20	.8	.72	.48	80	<input checked="" type="checkbox"/>
30	FB25	.7	.63	.42	20	<input type="checkbox"/>
40	FB30	.6	.4212	.6	100	<input checked="" type="checkbox"/>

Routing Details    Routing Network    Operation Resources

2. Choose the Operation Yield tab.

The values you entered for operation sequence and operation code number are displayed in this tab.

3. In the Yield field, enter a value for component yield for first operation.

This is the percent of the amount of a component required for an assembly plus the amount lost while building an assembly. For example, a yield factor of 0.90 means that only 90% of the usage quantity of the component on a bill actually becomes part of the finished assembly.

4. Check the Include in Rollup check box if you want the items, resources, and overhead in this operation to be included in the cost rollup. Otherwise leave the box unchecked.

The Include in Rollup check box defines if the operation is going to be included in the standard cost rollup. All operations, both primary and alternate, are defined on this form. You do not want all operations, both primary and alternate, to be included in the standard cost. When checking the box, make sure you want that operation to be included. If all operations are checked, including operations in the alternate paths, this would lead to an exaggerated standard cost and could create large variances.

Ideally, you should check the Include in Rollup flag for all operations on the primary path.

**Note:** Oracle Shop Floor Management only uses the standard costing method.

5. Select the Operation Yield indicator if you want this operation's yield to be calculated.

6. Repeat steps 3 through 7 for all the operations in the routing.
7. Save your work.

### **To calculate cumulative yield and reverse cumulative yield:**

1. Navigate to the Routings window and enter the item number.
2. Choose the Operation Yield tab.
3. Select Calculate Operation Yields from the Tools menu.

This will calculate cumulative yield and reverse cumulative yield for the routing. When the calculations are computed, a note will appear letting you know the process is complete. Choose OK in the Note window. The CUM Yield, Reverse CUM Yield, and Net Planning % fields are then populated.

4. Save your work.

## **Integration with Advanced Supply Chain Planning**

If you set the WSM: Create Job Level BOM and Routing Copies profile option to No (Option 1), then Network Routings are captured in a snapshot and used to calculate and plan resource requirements for existing lot based jobs and planned orders. If you set the WSM: Create Job Level BOM and Routing Copies profile option to Yes (Option 2), then the job-level routing is looked at and not the network routing of the item.

This is accomplished using one the following methods:

- The primary path
- Cumulative percentages
- Deriving the percentages based on resource availability

With the primary path method, orders are scheduled on the primary path. The cumulative percentages method takes advantage of the pre-calculated accumulated percentages from various paths on the network routing to guide scheduling. The third method, derives percentages based on resource availability, analyzes the current conditions on the shop floor and intelligently chooses alternate paths and determines the quantity which needs to be processed on each path.

The reverse cumulative yields specified at the operation sequence level are captured in a snapshot by Advanced Supply Chain Planning and used to derive the component requirements. Advanced Supply Chain Planning loads resources using the inflated quantities derived from reverse cumulative yields at different operation sequences.

### **See Also**

Oracle Advanced Supply Chain Planning, *Oracle Advanced Supply Chain Planning User's Guide* .

Constraint Types, *Oracle Advanced Supply Chain Planning User's Guide*.

Items, *Oracle Advanced Supply Chain Planning User's Guide*.

Manufacturing Resources, *Oracle Advanced Supply Chain Planning User's Guide*.

## Integration with Outside Processing

Using Outside Processing (OSP), you can include supplier-sourced components and resources in the manufacturing process. An OSP operation requires one or more OSP resources, which in turn must be associated with departments with location. In addition, a separate OSP item must be created to receive and charge the outside work (this item is associated with the resource). When creating the OSP item, the Purchasing Tabs of the Item window must have OSP-related settings, i.e. Purchased, Purchasable, Outside Processing Item must be checked. The list price must be specified in the purchasing master organization for generating purchase orders. See: Outside Processing , Oracle Work in Process User's Guide

- Setup
- Outside Processing Scenarios
- Job Creation/Update
- WIP Lot Transactions
- Move Transactions
- Defining Network Routings

---

## Lot Transactions

This chapter covers the following topics:

- Overview of Lot Transactions
- Creating a Lot Based Job
- Overview of Lot Moves
- Performing Lot Move Transactions
- Operation Jumps
- Viewing Status and Resources
- Integration with Oracle Advanced Supply Chain Planning (ASCP)
- Capturing and Modifying Detailed Job Level Plan Recommendations
- Changing the Recommended Path of a Job to Any Other Intended Path for Future Operations
- Viewing Plan Resource Details
- Updating Plan Components
- Updating Plan Phantom Components
- Mass Refresh of Open Jobs
- Overview of Advanced Lot Transactions
- WIP Lot Transactions
- Creating WIP Lot Transactions
- Inventory Lot Transactions
- Creating Inventory Lot Transactions
- Creating Lots for New Sectors
- Kanban Replenishment on Lot Based Jobs
- Lot Based Job Reporting
- Lot Based Job Component Pick Release
- Pending Transactions Report
- Integration with Outside Processing

## Overview of Lot Transactions

Oracle Shop Floor Management uses WIP lots and Inventory lots to create transactions. WIP lot transactions let you perform various work in process transactions during the production cycle, such as lot split, merge, part number change, and bonus (creating a new lot that is entirely new or from scrap).

The process flow of a lot begins when a WIP lot based job is created for the first sector's primary assembly. The WIP lot is created and released, moves through a series of operations, and is completed into an inventory location where it is an inventory lot. Upon completion, the WIP lot has the sector extension code appended that is assigned to the corresponding item subinventory. You can continue to use the same job name or lot name throughout the production process where the part number changes with each sector. For the bill of material, the part being completed in a sector becomes the primary component of the part being made in the next sector.

The Inventory lot then moves into the next sector. This move consists of creating a new WIP lot for the primary assembly of the next bill level (the next sector), and issuing the primary assembly from the previous sector to this new WIP lot. After WIP lot creation and issue of the primary component, the job moves through a series of operations, and is completed into inventory location. This process is repeated through each sector until the last sector is complete.

If you set the WSM: Create Job Level BOM and Routing Copies profile option to Yes (Option 2), then Oracle Shop Floor Management stores detailed information for each and every job. Making detailed job level changes is available only when you choose Option 2. During manufacturing execution, Option 2 lets you make job level changes as follows:

- Changing the recommended path of a job to any other valid intended path for future operations.
- Changing component requirements or specifying component substitutes for future operations.
- Using alternate resources. This is done through the resource centric workbench.
- Using the workbench to reassign job operations to different time periods.
- A new html User Interface (UI) provides detailed planning recommendations on the components, resources, and the network path of a job. Similar changes to the job can also be accomplished through open interface tables.

**Note:** Lot based jobs are not considered in the Oracle Master Scheduling and MRP, Oracle Order Management, or Oracle Project Management applications.

## Creating a Lot Based Job

After you have completed setup steps for defining your item numbers, assemblies, bills of material, and network routings—the next step is to create a lot based job for the first sector. The Lot Based Jobs window is used to define lots for the first sector of the manufacturing process and links them to assemblies on the shop floor. The lots for the other sectors are created using the Lot Creation window, see: [Creating Lots for New Sectors](#), page 4-28.

You cannot create lot based jobs for serial number controlled assemblies. This restriction applies to the jobs created using windows and interfaces.

**Note:** Lot based jobs support operation pull, push, and phantom supply types. Other supply types are not currently supported.

## Non-standard Lot Based Jobs

You can create non-standard lot based jobs. Standard jobs control the material, resources, and operations required to build an assembly and collect costs. Non-standard jobs control material and collect costs for miscellaneous activity. These jobs can be used on expense work orders for testing, prototypes, and rework where operation yield costing is not considered. You can perform all transactions on a non-standard lot based job like moves, scraps, jumps, undos, completions, returns, material transactions; all WIP lot transactions like bonus, split, merge, update routing, update assembly, update quantity and update lot name. Non-standard lot based jobs use WIP accounting class type *Expense Non-standard Lot Based*. See: *WIP Accounting Classes, Oracle Work in Process User's Guide*.

For non-standard jobs, you can choose whether to specify a subinventory or not. Thus subinventory is defaulted during job creation. If a subinventory is specified, you can complete the job into an inventory lot.

You can perform the update of bom and routing reference id's provided the job is unreleased. To update any reference id, you have to provide the reference id, revision date and the alternate designator.

If you set the WSM: Create Job Level BOM and Routing Copies profile option to Yes (Option 2), then job copies are created. If you set the WSM: Create Job Level BOM and Routing Copies profile option to No (Option 1), then job copies are not created.

## See Also

Overview of Setting Up, *Oracle Inventory User's Guide*

Overview of Setting Up, *Oracle Bills of Material User's Guide*

Creating a Network Routing, page 3- 3

Closing Lot Based Jobs, page 9- 1

## To find lot based jobs:

1. Navigate to the Lot Based Jobs window.  
The Find Lot Based Jobs window displays.

2. Enter your search criteria.

You can query by job name, assembly, accounting class, a range of start dates, a range of completion dates, or job status. You can combine or omit criteria as required.

Find Lot Based Jobs (M4)

Jobs  ... -

Type

Assembly

Schedule Group

Build Seqs  -

Class

Start Dates  -

Completion Dates  -

Status

Unreleased  Released

Complete  On Hold

**Closed**

3. Choose Find to display the Lot Based Jobs Summary window.
  - Select a lot based job and choose one of the following actions.
  - View Genealogy to view historical informations in the Lot Genealogy window, see: Displaying Genealogy and Where used Views, page 6- 2 .
  - The Operations window is used to view the resource requirement for the lot-based job.
  - The lot-based job provides the resource details for the first operation during job creation and the resource requirement for the other operations are shown whenever the job is moved to this operation.
  - Components to access the Material Requirements window displaying all the components for this job
  - Open to display the details of this job in the Lot Based Jobs window.
  - If you set the WSM: Create Job Level BOM and Routing Copies profile option to Yes (Option 2), then you can choose Plan Details from the Tools menu to open the UI and display the planned operation details.



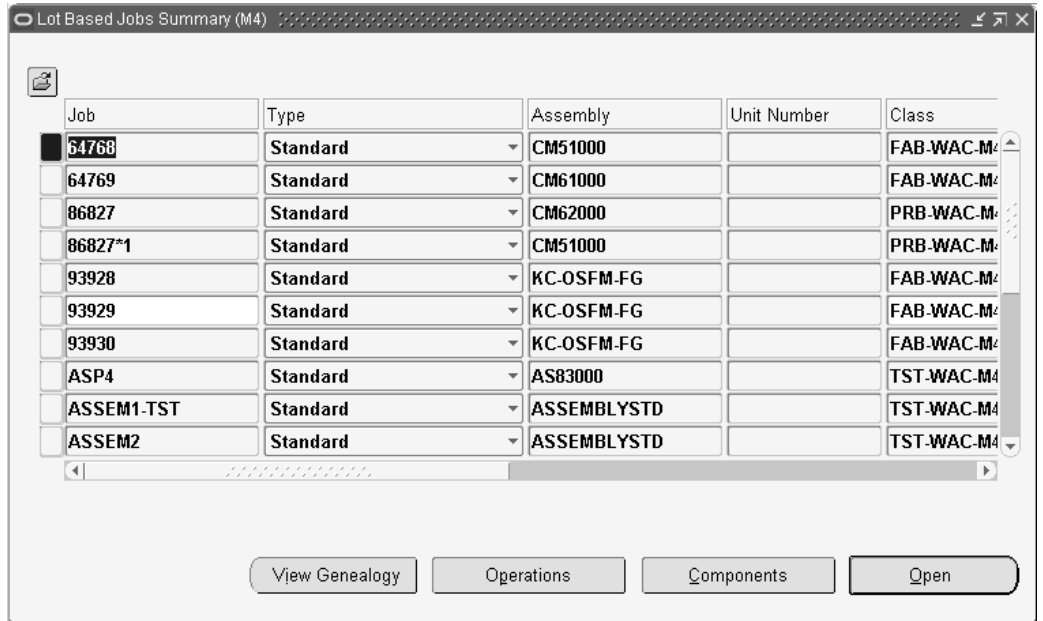

4. If you are creating a new lot, Choose New (A).

#### To create lot based jobs

1. Navigate to the Lot Based Jobs window. The Find Lot Based Jobs window displays.
2. If you are creating a new lot, Choose New (A). The Lot Based Jobs window opens.
3. Enter the name of the job in the Job field.

Oracle Work in Process discrete jobs and Shop Floor Management lot based jobs must not use the same value for Job name. In the Job Type field, the value defaults to standard. Oracle Shop Floor Management uses both standard and non-standard jobs.

As you proceed with the manufacturing process, the job name changes as lots are created, split, renamed, and completed. Keep in mind when creating lots that the name cannot exceed 30 characters. This includes the combination of sector extensions and lot separators appended to the resulting lot as it moves on the shop floor.

**Note:** Do not use the same character value for both the job completion separator, and in a segment of the job name. When lots are completed the resulting lot designation is the original lot number, followed by the job separator value, followed by the lot sector extension. Using the same character value creates an error in the resulting lot name.

4. Select the assembly in the Assembly field.

5. Select the job status in the Status field.  
When you define a job, its status defaults to Unreleased but can be changed to Release or On Hold.
6. Use the Firm indicator to firm this job.  
Firming a job prevents planning suggestions for rescheduling. However, lot-based jobs are not considered in the Oracle Master Scheduling and MRP, but are planned in Oracle Advanced Supply Chain Planning. This field is not used by non-standard jobs.
7. In the Quantities region, enter the Job quantity of the job or lot in the Start field.  
When you enter a Job start quantity for the Lot Based job using bills and routings, the component material requirements and resource equipment for the First Operation will be exploded into this Job.  
You can change the quantity on jobs with out transactions.
8. In the MRP net field, the quantity is derived from the job start quantity.  
Oracle Shop Floor Management does not integrate with Oracle Master Scheduling/MRP. This field supports Oracle Advanced Planning and Scheduling, applications.
9. In the Dates region, enter a value in either the Start or Completion field.  
If you enter a start date, the completion date is forward scheduled. Similarly, if you enter a completion date, the start date is backward scheduled.
10. Save your work.

**Note:** Lot based jobs create the material and resource requirement for the first operation only. The material and resource requirement is exploded whenever the job is moved to the corresponding operation, including the last operation.

If you are using Option 2 functionality, then you can view all planned operation details by choosing Launch Plan Details from the Tools menu.

### **To assign an alternate bill of material or revision**

1. On the Bill tab in the Alternate field, select the alternate bill of material.
2. You can select an alternate bill of material if an alternate has been defined. See: Primary and Alternate Routings, *Oracle Bills of Material User's Guide*.
3. In the Revision field, select the bill of material revision.
4. Select the bill of material revision's date and time.  
Bill revision and date determine which version of the bill, and therefore which components are on the bill of material.
5. In the Supply Type field, the value defaults to Operation Pull.  
Lot based jobs support only operation pull, push, and phantom supply types.
6. Save your work.

### **To assign the appropriate routing if the job has multiple routings**

1. On the Routing tab, select the routing you want to use in the Routing field.
2. Routings must be defined for this assembly, see: Creating a Network Routing, page 3- 3 .
3. In the Revision field, select the revision number of this routing.  
The date of the lot based job can be used to derive the routing revision.
4. In the Revision field, select the date and time if you want to update the values derived from the routing.
5. In the Subinventory field, the location (and locator, if existing) display for where this job completes.  
Subinventory fields default from the routing. They are not required for non-standard jobs—you can remove these values if this job will not be completed into inventory.
6. Save your work.

### **To schedule lot based jobs**

Enter or select either the Start and/or completion date and time. If you enter one date and time, the other date is calculated using the total lead time of the assembly.

### **To view component requirements**

Choose Components. The Material Requirements window displays showing all the components of this job.

If you set the WSM: Create Job Level BOM and Routing Copies profile option to No (Option 1), then you can view component requirements for completed and current operations only. If you set the WSM: Create Job Level BOM and Routing Copies profile option to Yes (Option 2), then you can also view component requirements for future planned operations.

## Viewing, Entering, and Updating Lot Attributes

### To view, enter, and update lot attributes

1. Choose Lot Attributes. The Lot Attributes window appears and displays the lot number and attributes of this job.

If you are entering or updating lot attributes, then enter or update attributes with appropriate values for Warehouse Management and Inventory attributes based on the lot attributes setup that you or your system administrator have completed.

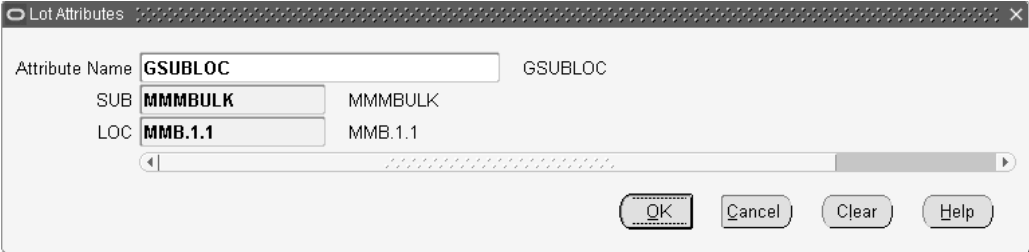

Attribute Name	SUB	LOC
GSUBLOC	MMMBULK	MMMBULK
MMB.1.1	MMB.1.1	MMB.1.1

2. Choose OK to save and return to the Lot Based Jobs window.
3. Choose Cancel if you do not want to save the lot attribute changes.

If you are only viewing the lot attributes without making changes, then you can choose OK or Cancel.

4. Save your work.

**Note:** If you do not enter a required segment value, then an error message appears. If you wish to view detailed information for an error message, then you must execute the concurrent request Get Messages using the parameter DB\_TO\_RUNTIME with a specific Language.

## Overview of Lot Moves

Lot-based jobs support network routing. Based on the results of an operation, you can define different paths for the next operation. Therefore, two distinct lot based jobs for a particular assembly with the same routing, could move through different manufacturing operations in that routing.

In comparison to the Move Transaction window for discrete jobs in Oracle Work in Process, the Move Lot Based Jobs window is more restrictive in the options when moving the lot through the routing. With the exception of scrap transactions, all move transactions are for the entire lot quantity. When a job is completed, the job name is automatically renamed using the lot sector extension, see: Defining and Viewing Lot Sector Extensions, page 2-11.

## Performing Lot Move Transactions

You can move assemblies within an operation or from one operation to the next using the Move Lot Based Job window. This window is modeled after the Move Transactions window in Oracle Work in Process. See: Move Transactions, *Oracle Work in Process User's Guide*.

You can execute all move transactions with scrap simultaneously during job execution from the move transactions user interface in the Move Lot Based Job window. This reduces the number of transactions, and captures good and bad quantity in the operation.

### Guidelines for Combined Move and Scrap Transactions:

- Generally, move and scrap will not work if the backflush flag in the Routing window on the From operation or the To operation is turned off.
- If the Jump From Scrap parameter in the OSFM Parameters window is set to ignore operation, then you cannot scrap at the From operation when executing a Jump and Scrap.
- If the job is at the Queue of an operation and Run is a mandatory intra operation step, then you cannot execute a Move and Scrap in that operation. You must first move to Run, and then Move and Scrap will work.
- If run of the next operation is mandatory, then you cannot move and scrap in the next operation. Move and scrap is possible in the From operation if the Run in the From operation is not mandatory.

If you set the WSM: Create Job Level BOM and Routing Copies profile option to Yes (Option 2), and you are using Oracle Advanced Planning, then the To Operations field in the Move Lot Based Job window provides guidance on the next recommended operation based on Oracle Advanced Planning inputs, or the user recommendations, whichever is the most recent.

### To perform lot move transactions:

1. Navigate to the Move Lot Based Jobs window. See: Performing Move Transactions, *Oracle Work in Process User's Guide*.
2. In the Assembly or Job field, select either an item assembly number or lot job number. Depending on which value you enter, the defaulting information for the corresponding field displays.

Assembly   Routing Revision   
 Job   UOM  Bill Revision

**Transaction Type**  
 Move  Undo  
 Complete  Jump  
 Return

**Operations**

	Job Seq	Code	Department	Step
From	<input type="text" value="10"/>	<input type="text" value="PB10"/>	<input type="text" value="Probe"/>	<input type="text" value="Queue"/>
To	<input type="text" value="20"/>	<input type="text" value="PB20"/>	<input type="text" value="Probe"/>	<input type="text" value="To move"/>

**Transaction**

UOM   
 Available   
 Move Quantity   
 Scrap Quantity   
 Scrap At Job Seq   
 Date

**Scrap Account**

Alias   
 Number   
 Reason   
 Reference  [ ]

Manual Resources Exist

3. Move displays in the Transaction Type region.

Move transaction type indicates moving from one operation to another. Complete transaction type is active only when the job is moving to the last operation and last intra-operation step. See: *Move Transaction Types, Oracle Work in Process User's Guide*.

Select the Undo Last Move check box if you want the option of cancelling the last move transaction. The Undo Last Move indicator on the Shop Floor Parameter window must be selected to enable this functionality.

4. In the Operations region, enter operation sequence values in the To row.

Values in the From row are defaulted based on the current status of the lot job. The information for Operation Code, Department, and Operation Step automatically displays, see: *Operations, Oracle Bills of Material User's Guide*.

The To row permits moves only to those operations which are valid, based on network. However, you can jump to any operation not defined in the network routing. See: *Operation Jumps, page 4-12*.

5. If there is quantity to scrap, enter Scrap Quantity in the Transaction region.
6. Enter the Scrap At Job Seq to define the operation wherein the quantity should be scrapped. You can scrap at the From operation or the To operation.

Scrap At Job Seq is enabled only for intraoperation moves (from one operation to another.) From and To refer to the operation sequence number, not the intraoperation step.

When executing a move and scrap transaction at the first operation, you cannot scrap and move in one step. This must be completed in two steps, and Lot Genealogy will display as a scrap transaction followed by a move transaction. See: *Operations, Oracle Inventory User's Guide*.

If the estimated scrap accounting is enabled, and you are moving material to scrap in this transaction, then Alias information displays in the Scrap Account region. Otherwise, it will be a blank field that you can update.

The scrap account alias number is an easily recognized name or label representing an account charged on miscellaneous transactions. This is used for viewing, reporting, and reserving. The scrap account number displays. See: Defining Account Aliases, *Oracle Inventory User's Guide*.

7. If manual resources exist for the completed operation, then the Manual Resource Exist indicator is selected. If there are Manual resources at the operation that is being completed, then the application notifies you that manual resources exist at the operation so that you can manually charge them. See: Charging Resources with Move Transactions, *Oracle Work in Process User's Guide*.
8. In the Reason field, select a transaction reason. See: Defining Transaction Reasons, *Oracle Inventory User's Guide*.
9. In the Reference field, enter any descriptive information to identify transactions, used on standard reports.
10. Choose Save to save the transaction.
11. If the supply type of the component at the operation is Operation Pull, then the Backflush window displays any consolidated component requirements for the move and scrap (if scrap is applicable) as a single transaction, . If the item quantities, and the lot and serial numbers are correct, then choose Done to complete the move and scrap transaction.

**Note:** You can update the material requirements for the current operation using the Update Material Requirements window. However, if you undo the transaction and execute a forward move to the same operation, then the application backflushes the components according to the BOM option A, and copy tables in option A. Any change in material requirements done before that operation will be lost. You can change material requirements for future operations using the html UI. These material requirement changes will be referenced and never deleted.

### To view, enter, and update lot attributes:

Choose Lot Attributes. The Lot Attributes window appears and displays the lot number and attributes of this job.

12. Choose Attributes in the Lot Attributes window. A new Lot Attributes window appears.

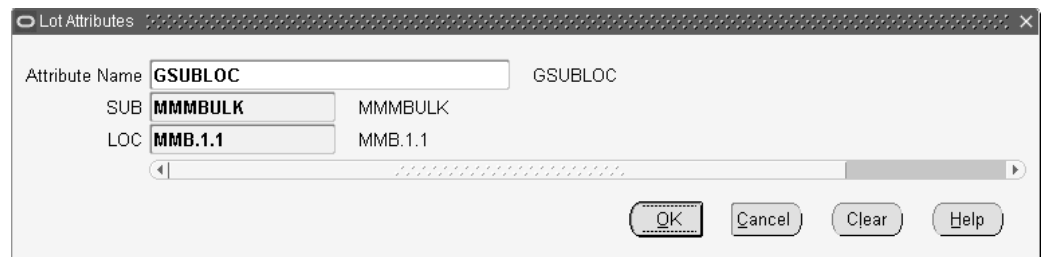

13. Select an Attribute from the list of values.

14. Enter parameter and segment values.
15. Choose OK.
16. Save your work.

## Operation Jumps

The operation jump functionality enables you to skip operations in a routing, or jump to any operation not defined in the network routing. To use this functionality, set the following parameters:

- Oracle Shop Floor Management profile option, Allow Operation Jumps is set to Yes. See: Profile Options, page 2-15
- Work in Process Parameters window, set the Move Transaction Parameter—Allow Creation of New Operations—to Yes
- Oracle Shop Floor Management Parameters window, set the parameter Jump From Queue according to your need. See: Defining Parameters, page 2-7.

### To perform an operation jump:

1. Navigate to the Move Lot Based Jobs window.
2. In the Assembly or Job field, select either an item assembly number or lot job number.

Depending on which value you enter, the defaulting information for the From the Transaction Type region, check the Jump check box.

The screenshot shows the 'Move Lot Based Job (M4)' window. At the top, it displays 'Assembly SMC2400' and 'Job SMC1400A'. Other fields include 'Processed Wafer', 'Original SMC1400 qty: 1000', 'UOM Ea', 'Routing Revision 0', and 'Bill Revision 0'. The 'Transaction Type' section has radio buttons for 'Move' (selected), 'Complete', and 'Return', along with checkboxes for 'Undo' and 'Jump' (checked). The 'Operations' table shows a jump from Job Seq 10 to 20, with Code FOS1 to AS20, Department FAB to Assembly, and Step Queue to To move. The 'Transaction' section includes fields for UOM (Ea), Available (1000), Move Quantity (1000), Scrap Quantity (0), Scrap At Job Seq, and Date (23-NOV-2004 14:40:29). The 'Scrap Account' section has fields for Alias, Number, Reason, and Reference. At the bottom, there are buttons for 'Lot Attributes', 'Statuses', 'Resources', and 'Save (E)'. A checkbox 'Manual Resources Exist' is also present.

3. In the To row, enter any operation sequence number which is greater than the From operation sequence number.
4. Select an operation code and the step for the operation to which you want to jump.
5. Create remaining transactions as described in Creating Lot Move Transactions, page 4-9.



After completing the jump operation, you can move to any of the operations defined in the original routing to complete the balance of operations.

6. Save your work.

## Viewing Status and Resources

### To view shop floor statuses:

Choose Statuses. See: Assigning and Viewing Shop Floor Statuses, *Oracle Work in Process User's Guide*.

### To view shop floor resources:

Choose Resources. See: Charging Resources with Move Transactions, *Oracle Work in Process User's Guide*.

## Integration with Oracle Advanced Supply Chain Planning (ASCP)

If you set the WSM: Create Job Level BOM and Routing Copies profile option to Yes (Option2), then Oracle Shop Floor Management integrates with Oracle Advanced Planning and Scheduling. Oracle Advanced Planning collects data for lot based jobs on the shop floor and performs high level planning, and suggests creation of new lot based jobs, if required. Lot based jobs contain plan information. This plan information comes from the following three sources:

- Oracle Advanced Planning modifies plans for existing jobs, or specifies plans for the newly created jobs.
- You can change the plan information on the lot based job.

You can specify or change the following on a lot based job, one job at a time:

- Specify or change the path that is planned to be traversed on the network routing. This involves operations that you intend to perform for this job that form a path on the network routing.
- Specify or change the component that is used for the operations. You can specify substitute components on the routing. You can indicate your preference of which component to use among the alternates that are available.
- Specify or change the resources used for the operations. You can specify alternate resources on a network routing and can indicate your preference of which resource to use. If the resource has instances, then you can specify the specific instance that would be used for the specific lot based job.

The Oracle Shop Floor User Interface (UI) for capturing and altering planning preferences is an enhancement to the shop floor scheduling process. The UI for capturing and altering planning preferences streamlines the shop floor scheduling process. You can access the UI for capturing and altering planning preferences through a BLAF-compliant web interface.

## Capturing and Modifying Detailed Job Level Plan Recommendations

If you set the WSM: Create Job Level BOM and Routing Copies profile option to Yes (Option 2), then you can capture and modify detailed Oracle Advanced Planning recommendations for job and operation start dates, completion dates, component details, and resource details. You must also choose the primary path planning option in the planning parameters of Oracle APS. The application uses recommendations on component substitutes and alternate resources received from planning and scheduling systems, or you can enter these manually.

Oracle Advanced Planning plans materials and resources for a job based on the primary path of the routing. During execution, you can change the planned execution as follows:

- Changing the recommended path of a job to any other intended path for future operations.
- Changing component requirements or specifying component substitutes for future operations.
- Using alternate resources. This is done through the resource centric workbench.
- Change planned operation yield.

A HTML User Interface (UI) provides detailed planning recommendations on the components, resources, and the network path of a job. You can use this UI to make any job level changes described above, except changing to alternate resources. See: Rescheduling Jobs, Operations, and Resources in the Gantt Chart, page 5-12

You can also implement all Oracle Advanced Planning recommendations and changes using open interface tables. Interfaces can be used to populate data from third party planning applications.

## Changing the Recommended Path of a Job to Any Other Intended Path for Future Operations

You can change the recommended path of a job to any other intended path for future operations using the Update Plan Recommended Path UI window.

### To update the plan recommended path:

1. Navigate to the Lot Based jobs window and open a job.
2. Select Plan Details from the tools menu.

The Oracle Shop Floor Management HTML Plan Details UI window appears. The Header region displays job details and the Operations region displays operations for the job. In the Operations region, the default view shows the recommended operations in their order on the recommended path. The view can be changed to show all operations.

Plan Details: comp10

Job Description	<b>Original CM60000 qty: 1</b>	Quantity Remaining	<b>1</b>
Assembly	<b>CM61000</b>	UOM	<b>Ea</b>
Assembly Description	<b>Processed Wafer</b>	Coproducts Supply	<b>Yes</b>
Released Date	<b>15-Dec-2004 10:01:15</b>	Current Routing Operation Sequence	<b>30</b>
Scheduled Start Date	<b>15-Dec-2004 10:00:50</b>	Current Operation Code	<b>FB25</b>
Scheduled Completion Date	<b>15-Dec-2004 10:01:51</b>	Current Operation Department	<b>FAB</b>
Requested Due Date		Routing Refresh Date	<b>15-Dec-2004 10:01:16</b>

[Personalize Region](#)  
[▶ Show Additional Details](#)

Operations

View  ▾

[Personalize Region](#)

Routing Operation Sequence	Code	Department	Operation Description	Start Date	Completion Date	Scheduled Quantity	Yield	Details
10	FB10	FAB	Load Stepper Machine	15-Dec-2004 10:00:50	15-Dec-2004 10:01:26	1	0.5	
20	FB20	FAB	Stepper Machine	15-Dec-2004 10:01:26	15-Dec-2004 10:01:33	0.5	1	
30	FB25	FAB	Stepper Machine 2				1	
40	FB30	FAB	Unload Stepper Machine	15-Dec-2004 10:01:33	15-Dec-2004 10:01:51	0.5	1	

[Personalize Region](#)  
[Personalize Region](#)

- Choose Update Recommended Path in the operations region to make changes to the recommended components and quantities. The Update Recommended Path UI window appears. Select or clear the recommendations to create a new recommended path.

Plan Details: comp10 >

Update Recommended Path: comp10

Job Name	<b>comp10</b>	Job Description	<b>Original CM60000 qty: 1</b>	<input type="button" value="Cancel"/>	<input type="button" value="Apply"/>
Assembly	<b>CM61000</b>	Assembly Description	<b>Processed Wafer</b>		
Routing Reference		Alternate Routing Designator			
Routing Revision Date	<b>15-Dec-2004 10:01:14</b>	Routing Revision	<b>0</b>		

Details	From Sequence	From Code	To Sequence	To Code	Planning Percent	Recommended	Transition Type
▶ Show 10		FB10	20	FB20	100	<input checked="" type="checkbox"/>	Primary
▶ Show 20		FB20	30	FB25	20	<input checked="" type="checkbox"/>	Alternate
▶ Show 20		FB20	40	FB30	80	<input type="checkbox"/>	Primary
▶ Show 30		FB25	40	FB30	100	<input checked="" type="checkbox"/>	Alternate

[Personalize Region](#)  
[Personalize Region](#)

- Choose Apply to save your changes and return to the Plan Details UI window, or choose cancel to discard any changes..

## Viewing Plan Resource Details

You can view details for a recommended resource, and view alternate resources using the Plan Resource Details window from the html UI.

## To view plan resource details for a recommended resource:

1. Navigate to the Lot Based Jobs window and open a job.
2. Select Plan Details from the tools menu. The Plan Details UI window appears.
3. Choose Details from a Routing Operation Sequence. The Plan Operation Details UI displays.
4. Choose Details.

The Plan Resource Details window appears.

ORACLE Shop Floor Management

Plan Details: comp10 >  
Operation: 20

Operation Seq Num **20** Scheduled Quantity **0.5**  
Operation Code **FB20** Start Date **15-Dec-2004 10:01:26**  
Department **FAB** Completion Date **15-Dec-2004 10:01:33**  
\* Cumulative Yield

► Show Details  
Personalize Region

Resources Components

Select Component: (Update)

Select Details	Component	Required Quantity	Onhand Quantity	UOM	Quantity Per Assembly	Component Yield	Date Required	Supply Type	Supply Subinventory	Supply Locator	Source Phantom
► Show	CM51000	0.5	85	Ea	1	1	15-Dec-2004 10:01:26	Operation Pull	Stores		AS80001

Personalize Region  
Personalize Region

Resources Components

Copyright 2000-2004 Oracle Corporation. All rights reserved.  
About this Page

Privacy Statement

## Updating Plan Components

You can view and change the recommended plan components using the Update Components UI window.

### To update the recommended plan components:

1. Navigate to the Lot Based Jobs window and open a job.
2. Select Plan Details from the tools menu. The Plan Details UI window appears.
3. Choose the Details icon for a Routing Operation Sequence. The Plan Resources and Components Details UI window appears.

Plan Details: comp10 >

Operation: 20

Operation Seq Num **20** Scheduled Quantity **0.5**  
 Operation Code **FB20** Start Date **15-Dec-2004 10:01:26**  
 Department **FAB** Completion Date **15-Dec-2004 10:01:33**

\* Cumulative Yield

[Show Details](#)  
[Personalize Region](#)

Select Component:

Select Details	Component	Required Quantity	Onhand Quantity	UOM	Quantity Per Assembly	Component Yield	Date Required	Supply Type	Supply Subinventory	Supply Locator	Source Phantom
<input type="radio"/> <a href="#">Show</a>	CM51000	0.5	85	Ea	1	1	15-Dec-2004 10:01:26	Operation Pull	Stores		AS80001

[Personalize Region](#)

[Personalize Region](#)

4. Choose Components to display component information.
5. Select a Component and choose Update.
6. Select a component line and choose Recommend. The Update Components UI window appears.

Plan Details: comp10 > Operation: 10 >

Update Component: CM60000

Operation Seq Num **10** Operation Code **FB10**  
 Operation Department **FAB** Scheduled Quantity **1**  
 Backflush **Yes**

[Personalize Region](#)

Select Component:

Select Component	Assembly	Quantity Per	Component Yield	Supply Type	Supply Subinventory	Supply Locator	Required Quantity	Onhand Quantity	UOM	Primary	Recommended
<input type="radio"/>	CM60000	1	1	Assembly Pull	Stores		<input type="text" value="1.57"/>	57	Ea	<input checked="" type="checkbox"/>	<input checked="" type="checkbox"/>

[Personalize Region](#)

7. Enter any changes to Required Quantity and choose Apply to save your changes. Choose Cancel to discard any changes and return to the Plan Resources and Components window.

**Note:** If you make changes to the plan details of an operation through the HTML UI, then changes are effective the next time

you come to that operation. If you want to make changes to the current operation in real time, then you must make changes using WIP windows.

## Updating Plan Phantom Components

You can use the Update Phantom Component UI window to view and change the recommended phantom components. If you have a BOM with the phantom supply type for one of the components, then you can view phantom details in the UI. If you have substitutes for an item, then you can also choose substitutes. See: *Phantoms*, page 1- 2 and *Phantom Routings*, page 8- 2 .

See also: *Phantoms in Lot Based Jobs*, *Oracle Bills of Material User's Guide*.

### To update plan phantom components:

1. Navigate to the Lot Based Jobs window and open a job.
2. Choose Plan Details from the Tools menu. The Plan Details UI window appears.
3. Choose the Details icon for a Routing Operation Sequence. The Plan Resource and Components UI window appears.
4. Choose Components to display component information.
5. Select the Phantom component that you want to make changes to, and choose Update.
6. Select a phantom component and choose Recommend. The Update Phantoms UI window appears.

ORACLE Shop Floor Management Diagnostics Close Window Preferences Personalize Page

Plan Details: comp10 > Operation: 20 >  
 Update Phantom Component: CM51000 Cancel Apply

Operation Seq Num **20** Operation Code **FB20**  
 Operation Department **FAB** Scheduled Quantity **0.5**  
 Backflush **Yes**

Personalize Region

Select Phantom: (Recommend)

Select Details	Phantom Description	Phantom Assembly	Phantom Quantity Per Assembly	Phantom Yield Factor	Phantom Required Quantity	UOM	Primary Phantom	Recommended
<input type="checkbox"/>	AS80001 Final Chip Assembly High Grade		1	1	0.5	Ea	<input checked="" type="checkbox"/>	<input checked="" type="checkbox"/>

Components

Component Phantom	Quantity Per Phantom	Component Yield	Date Required	Supply Type	Supply Subinventory	Supply Locator	Required Quantity	Onhand Quantity	UOM
CM51000	1	1	15-Dec-2004	Operation Pull	Stores		0.5	85	Ea

Personalize Region Cancel Apply

Copyright 2000-2004 Oracle Corporation. All rights reserved. Diagnostics | Close Window | Preferences | Personalize Page  
 About this Page Privacy Statement

7. Select the Phantom and enter any Required Quantity changes. Choose Apply to save changes, or choose cancel to discard any changes and return to the Plan Resources and Components UI window.

## Mass Refresh of Open Jobs

Changes in Bills of Material (BOM) and Routings are not currently distributed to open jobs at the shop floor. By default, this concurrent program does not refresh copies of any open lot based jobs. These changes come into effect only when new jobs are created. If you set the WSM: Create Job Level BOM and Routing Copies profile option to Yes (Option 2), then you can update changes in all open lot based jobs, or a user defined subset of these jobs by using the Refresh Open Job Copies concurrent program. By default, changes are not saved to the open jobs, and you must set parameters as described below.

### To update open lot based jobs:

1. Navigate to the WSM\_REFRESH\_JOBS Parameters window.
2. Enter Yes or No to Refresh All Open Jobs. (Required)

You can refresh all open jobs with any status except Closed by entering Yes for Refresh All Open Jobs. If this value is Yes, then the application ignores all other search parameters, and refreshes BOM and Routing copies for all open lot based jobs in the current organization. If this value is No, then additional job selection criteria is required.

3. Enter a range of jobs to refresh in the From Job Name and To Job Name fields. (Optional)

Refresh All Open Jobs	No
From Job Name	90221
To Job Name	90221
Job Assembly	
Job Type	Standard
Common Bill Item	
Alternate Bill Designator	
Common Routing Item	
Alternate Routing Designator	
Select Jobs by Status	Yes
Released Jobs	No
Unreleased Jobs	No
On Hold Jobs	No
Complete Jobs	No
Closed Jobs	No

4. Enter a Job Assembly. (Optional)
5. Enter the Job Type. (Optional)
6. Enter a Common Bill Item and Alternate Bill Designator. (Optional)
7. Enter a Common Routing Item and Alternate Routing Designator. (Optional)

8. Enter Yes or No to Select Jobs by Status.

If you select No, then the application refreshes the specified jobs and does not consider job status. If you select Yes, then the application considers each of the job status values that you select.

9. Choose OK.

The WSM\_REFRESH\_JOBS window displays the request information.

10. Choose Submit.

**Note:** If the Refresh Open Job Copies concurrent program runs, and the Infinite Scheduler program runs to assign dates on the jobs. If scheduled dates are not available, the Resource Centric Workbench will not show these jobs or operations in the Workbench user interface.

Refresh Open Job Copies updates copy tables, but does not refresh current operation information. Refreshing copy tables is intended to update future operations with changes. Any changes made to the current operation from the User Interface are not captured by the Resource Scheduling Workbench or lot based job. If you intend to make changes to current operations, then you must use WIP windows.

## Overview of Advanced Lot Transactions

Oracle Shop Floor Management provides the ability to split lots, merge lots, and perform additional other advanced lot transactions. Lots exist at different production points as either WIP lots or Inventory lots. Two windows, one for the WIP lot and the other for Inventory lot, give you the ability to perform various work in process and inventory transactions so you can divide, combine, rename existing lots, or create new lots from scrapped material. These windows enable you to do the following actions:

### WIP Lot Transactions

- *Lot Splitting:* divide a lot into two or more resulting lots: split a released lot into two or more resulting lots that can have different resource, material requirements, and different operations.
- *Lot Merging:* combine multiple lots of the same item into one resulting lot. The jobs to be merged must be at the same operation, department and intraoperation step. Identical assemblies are not required.
- *Update Assembly:* change the item, quantity, or revision of an existing lot and move it to another assembly. The lot number is renamed in these transactions.
- *Bonus:* recover scrap quantities to create a new lot, or create an entirely new lot.

Use the WIP Lot Transactions window for these transactions.

### Inventory Lot Transactions

- *Subinventory Transfer:* move a lot from one subinventory/locator to another subinventory/ locator.

Use the Inventory Lot Transactions window for this transaction.



## WIP Lot Transactions

WIP Split and Merge functionality provides business solutions on the shop floor so you can do the following tasks:

**Lot Splitting:** You can divide a lot into any number of child lots. The parent lot can be at any operation in the routing and may have created material, resource and cost transactions. The split lots have a value proportional to the number of units being split away. Scrap and variance due to scrap are associated with the lot number in the scrap transaction. Child lots have their own routings and bills of material, and you can create transactions against different child lots immediately after a split. Backward movement for a split transaction is not allowed. The transaction processing for splits is not linked to the cost processing for splits, as transactions may be entered into the system via the interface at any time. When a lot is split into multiple children, the standard costs collected at the starting job are redistributed to the resulting jobs.

New lot numbers are automatically assigned to the child lots of a split transaction, but can be changed. New lots are independent entities linked by a transaction history associating their genealogy.

The split transaction can update the assembly of the child job while performing the split transaction. This provides greater flexibility and reduces the number of transactions. Support for combined split and update assembly transactions are also available through open interfaces.

**Lot Merging:** Multiple lots with identical assemblies can be combined to create a single parent lot. Only lots at the same intra-operation step are merged. The new job is now at the operation where the lots were merged.

**Lot Bonus:** You can increase the work order quantity, and credit a bonus account for the transaction. You can also simulate a recover transaction to start a lot on a given routing at a given step, and credit a bonus for the transaction.

**Update Assembly:** One product can be translated into another product—that is—change the item, quantity, revision, or routing of an existing lot and move it to another assembly. There are no costing implications in this transaction. You can also switch to an alternate routing on the same operation step.

If the translation is updating the routing, then the WIP lot is updated with an alternate network routing defined for the assembly. When this type of translation is performed at the queue intra-operation step, the operation characteristics correspond to the same operation, if existing, in the new routing. You can also update the routing revision, or routing revision date without changing the alternate designator. If you set the WSM: Create Job Level BOM and Routing Copies profile option to Yes (Option 2), then it is mandatory to provide the starting operation if the job is at a tomove intra-operation step. If you are using Option 1, then to provide the starting operation.

**Assigning Starting Operation for Child Lots:** A lot can be split into several child lots and processed on different routings, potentially creating other assemblies. Starting operation for the child lots is the same as the parent lot operation at the time of the split. For bonus lots, you can start a child lot at any operation sequence number on a given routing, otherwise it defaults to the queue step at the first operation. The operation history before the split is saved for all lots, used for scrap and standard cost update valuation.

**Note:** Wip lot transactions proceed when requisitions have been created for the current operation. A warning message appears prompting

you to proceed with the transaction, or cancel. If you execute the transaction, then you must cancel the requisitions manually.

## Creating WIP Lot Transactions

### To enter WIP lot transactions:

1. Navigate to the WIP Lot Transactions window.
2. Select a transaction type.

Your choices are Bonus, Merge, Split, Update Assembly, Update Lot Name, Update Quantity, or Update Routing. See: WIP Lot Transactions, page 4-21.

Status defaults to Pending, and is updated to Completed when the transaction is saved. The database does not store any records with a status of Pending.

Select the job type (standard or non standard) for the type of jobs the transaction is to be performed on. **Note:** WIP lot transactions cannot be performed across job types.

The Costed field is updated after costing program is executed.

3. In the Reference field, you can enter any descriptive information regarding this transaction.

The screenshot shows the 'WIP Lot Transactions (M4)' window. At the top, there are input fields for Transaction ID, Transaction Date, Status (set to 'Pending'), Transaction Type (set to 'Split'), Job Type (set to 'Standard'), and Costed. There are also fields for Reason and Reference.

The 'Starting Job' section has tabs for Job, Bill, Routing, Operation, and Others. It contains a table with columns: Job Name, Description, Type, Assembly, Available Quantity, and Net Planned. The first row is selected and shows: CM61000-JOB1, Original CM61000 qty: 10, Standard, CM62000, 10, 10.

The 'Resulting Job' section has tabs for Job, Bill, Routing, Start Operation, and Others. It contains a table with columns: Job Name, Description, Type, Update Assembly, Assembly, Resulting Quantity, and Net Planned. The first row is selected and shows: CM61000-JOB1\*, Original CM61000 qty: 10, Standard, [checkbox], CM62000, 5, 5.

Buttons for 'Lot Attributes', 'Cancel', and 'Save' are located at the bottom of the window.

4. Optionally, you can select the purpose of this transaction in the Reason field.
5. Follow the procedures for the transaction you want to create, Your choices are Bonus, Merge, Split, Update Assembly, Update Lot Name, Update Quantity, or
6. Update Routing.

**Note:** Wip lot transactions proceed when requisitions have been created for the current operation. A warning message appears prompting you to proceed with the transaction, or cancel. If you execute the transaction, then you must cancel the requisitions manually.

## Viewing, Entering, and Updating Lot Attributes

### To view lot attributes for the starting lots:

1. Choose Lot Attributes. If the starting lot has lot attributes, then the lot attributes window appears with attributes.
2. Choose WMS or INV attribute to view the individual segments of the respective attribute.
3. Choose OK when you are finished viewing the attributes.

### To view, enter, and update lot attributes for the resulting lot:

1. Choose Lot Attributes.
2. If you are entering or updating lot attributes, then enter and update attributes with appropriate values for WMS and INV attributes based on the lot attributes setup that you or your system administrator completed. The WMS attributes for the resulting lot are inherited from the starting lot only if the source and resulting lot's assemblies have the same context. In case of a merge transaction, the WMS attributes are inherited from the representative lot of the starting lot. The INV attributes are always inherited from the source lot whether the context of the source and resulting lot is same or not. In case of a merge transaction, the WMS attributes are inherited from the representative lot.
3. Choose OK to save and return to the WIP Lot Transactions window.
4. Choose Cancel if you do not want to save the lot attribute changes.

Lot Attributes

Attribute Name  GSUBLOC

SUB  MMMBULK

LOC  MMB.1.1

OK Cancel Clear Help

7.

### To create WIP lot bonus transactions:

Select the bonus transaction type.

8. In the Resulting Job region, in the Job Information tab, enter the new lot number.
9. Enter a lot number, description, assembly number, quantity, and bonus account number.

10. In the Others tab, the accounting class is defaulted but you can select another one from the list of values. You can start a bonus lot at any operation on the primary path, however, the default is the queue step at the first operation.
11. Optionally, you can change the Start and Completion dates.
12. You can also enter routing and bill of material information in the Routing Information and the BOM and More tabs.
13. Save your work.

#### **To create WIP lot merge transactions:**

Select the merge transaction type.

14. In the Starting Job region, in the Lot Number field, select the lot numbers of the parent lots you want to merge.

The lot details display: assembly number, operation sequence number, intra-operation step, operation code, quantity remaining in the lot, alternate routing, and start date.

15. Check the Representative Lot check box for one lot in this group whose characteristics will represent the merged lot.

The attributes of the representative lot are used for the resulting merged lot.

16. In the Resulting Job region, in the Job tab, enter the new lot number.

You can also select the name of any of the starting lots you are merging. The parent assembly number is transferred from the original lot number. The quantity in the Resulting Quantity field is the sum of all the original lots.

You cannot update Accounting Class for non-bonus WIP Lot transactions. You cannot update Start and Completion Dates except for any WIP transaction other than bonus where you can provide the start date and completion dates.

17. You can also enter routing and bill of material information in the Routing Information and the BOM and More tabs.

18. Save your work.

#### **To create WIP lot split transactions:**

Select the split transaction type.

19. In the Starting Job region, in the Lot Number field, select the lot number of the parent lot to split.

The lot details display: assembly number, operation sequence number, intra-operation step, operation code, quantity remaining in the lot, alternate routing, and start date.

20. In the Resulting Job region, in the Job tab, the new lot number displays.

The system automatically assigns a new lot number according to your setup in the Shop Floor Management Parameters window, see: Defining Parameters, page 2- 7 . When a lot is split, the new resulting lot designation is the original lot number, followed by the lot separator value set in the parameter, followed by sequential numbering.

The representative lot is transferred from the original lot number. Enter the quantity in the Resulting Quantity field.

21. Select the Change Assembly indicator to execute a split and update transaction.

The Change Assembly indicator is active only when you select the split transaction type. The split transaction can now update the assembly of the child job while performing the split transaction. You cannot clear (uncheck) this indicator, therefore, you must exit and open the window.

22. If you select the Change Assembly indicator, then enter a new Assembly and Resulting Quantity.

You cannot update Accounting Class for non-bonus WIP Lot transactions. You cannot update Start and Completion Dates except for any WIP transaction other than bonus where you can provide the start date and completion dates.

23. You can also enter routing and bill of material information in the Routing Information and the BOM and More tabs.

24. Save your work.

### To create WIP lot update transactions:

Select the update transaction type you want to perform.

Your choices are Update Assembly, Update Lot Name, Update Quantity, or Update Routing.

25. In the Starting Lot region, in the Lot Number field, select the lot number to update.

The lot details display: assembly number, operation sequence number, intra-operation stop, standard operation code, quantity remaining in the lot, alternate routing, and start date.

26. Different fields in the Resulting Lot region need to be updated, depending on which transaction you are creating.

For Update Assembly, in the Job Information tab, select the new assembly number in the Assembly field.

For Update Lot Name, in the Job Information tab, enter the new lot name in the Lot Number field.

For Update Quantity, in the Job Information tab, enter the new quantity in the Resulting quantity field.

Enter the bonus account number in the Others tab.

For Update Routing, add routing data in the Routing Information tab.

You cannot update Accounting Class for non-bonus WIP Lot transactions. You cannot update Start and Completion Dates except for any WIP transaction other than bonus where you can provide the start date and completion dates.

27. You can also enter routing and bill of material information in the Routing Information and the BOM and More tabs.

28. Save your work.

**Note:** While performing Update Routing or Update Assembly transactions at the Queue intraoperation step, if you have phantom

exploded components at the current operation—you must manually reverse the charges.

## Inventory Lot Transactions

- Inventory Lot transactions enable you to split, merge, translate, and transfer inventory lots in Oracle Shop Floor Management. You cannot execute inventory lot transactions for lot and serial controlled items. You have two methods of performing inventory lot transactions:
- Perform inventory lot transactions using OSFM windows
- Perform inventory lot transactions through the Oracle Warehouse Management mobile interface. See: *Mobile Interface, Oracle Warehouse Management*.

**Caution:** Different types of attributes, such as Inventory (INV) Item Lot and Warehouse Management (WMS) Item Lot, are not validated when performing inventory lot transactions using the OSFM windows. Item level attributes such as Lot Split Enabled and Lot Merge Enabled are not validated using OSFM windows, although they are enabled for Warehouse Management Mobile Interface.

When importing using an interface, the import fails and the log file contains an error message.

**Lot Splitting:** You can divide a lot into any number of child lots. The split lots have a value proportional to the number of units being split away. When a lot is split into multiple children, the costs allocated to the starting lot are reallocated to the resulting lots.

New lot numbers are automatically assigned to the child lots of a split transaction, and can be changed. New lots are independent entities linked by a transaction history associating their genealogy.

**Lot Merging:** Multiple lots with identical assemblies can be combined to create a single merged lot.

The assemblies for the lot is automatically moved to the current operation.

**Lot Translating:** Enables users to either change the name of an inventory lot to another name, or convert one product to another product. For example, you can change the lot name, item, revision, or subinventory of an existing lot and move it to another assembly. Lot genealogy captures all transactions.

**Lot Transferring:** A Lot can be moved from one subinventory location to another.

## Creating Inventory Lot Transactions

### To create inventory lot transactions:

1. Navigate to the Inventory Lot Transactions window.
2. Select a transaction type.  
Your choices are Split, Merge, Translate, Transfer. See: *Inventory Lot Transactions*, page 4-26.
3. The Transaction Date displays the current date, and you can change this date.

- Optionally, you can select the purpose of this transaction in the Reason field.
- In the Reference field, enter any descriptive information to identify transactions, used on standard reports.

Inventory Lot Transactions (WSM)

Transaction Type: Split  
Reason: VendError  
Reference: [ ]

Transaction Date: 20/JUL/2000 11:52:03  
Transaction Id: 50779

**Starting Lots**

Lot Number	Item	Rev	Quantity	Subinventory	Locator
BDM-Lot-1B-M-1	WSM_ITEM_D		5	Store02	

**Resulting Lots**

Lot Number	Item	Rev	Quantity	Subinventory	Locator
BDM-Lot-1B-M-1*1	WSM_ITEM_D		5	Store02	

Save

- In the Starting Lot region, select a lot in the Lot Number field.  
The lot details display: item number, quantity, subinventory location, and locator.  
In the Resulting Lot region, depending on the type of transaction you are creating, different information is needed to complete the transaction.
- For split transactions, select the lot to split in the Starting Lot region.  
In the Resulting Lot region—the system automatically assigns new lot numbers according to your setup in the Shop Floor Management Parameters window, see: Defining Parameters, page 2-7 . When new lots are created, the resulting lot designation is the original lot number, followed by the lot separator value set in the parameter, followed by sequential numbering.  
The lot details are transferred from the original lot number: item number, quantity, subinventory location, and locator. Enter the quantity of the new lot in the Quantity field. You can also change the subinventory location.  
If a coproduct definition is defined, then there should be no date in the future where the split percentages remain undefined. For this reason, you cannot change existing date ranges. If you want to change date ranges, then define new dates that overlap with existing dates.
- For merge transactions, select the lots to combine in the Starting Lot region.  
In the Resulting Lot region—the last lot number you select is the lot number used for all the merged lots. The system automatically assigns new lot numbers according to your setup in the Shop Floor Management Parameters window, see: Defining

Parameters, page 2-7 . When new lots are created, the resulting lot designation is the original lot number, followed by the value set in the parameter, followed by sequential numbering.

The lot details are transferred from the original lot number: item number, routing revision level, quantity, subinventory location, and locator. The quantity of the all the combined lots is the value in the Quantity field. You can change the subinventory location.

9. For lot translating transactions, select the lot you want to rename in the Starting Lot region.

In the Resulting Lot region—select the new name for the lot. You can change the item number in the Item field and the subinventory location, if required.

10. For lot transferring transactions, select the lot to move in the Starting Lot region.

In the Resulting Lot region—you can change the subinventory location.

11. Save your work.

## Creating Lots for New Sectors

The Assemblies manufactured in the first sector are getting completed into the respective subinventories. Now this lot is ready for the subsequent use in the next sector. The next step is to define the jobs in the subsequent sectors using the Lot Creation window. When a lot based job is created using lot the creation feature, it is assumed that the starting component is issued to this job. Therefore, the starting component is pushed into this job ignoring the supply type defined for the component in the first operation.

### To create lots on the shop floor:

1. Navigate to the Lot Creation window.
2. Select an Inventory lot number in the Starting Lot field.

Information displays for subinventory location, locator number, item number and description, revision number, quantity on hand, and quantity available to transact.

3. In the Job Information tab, the Resulting Lot designation displays and is the original lot number, followed by the New Lot Separator value, followed by sequential numbering. You can also define the revision number and revision date for Bill of Material and routing in order to use the component and operations effectivity.

Information displays in the following fields and can be changed: Accounting Class, Completion Subinventory and Locator.

**Note:** Please note that the starting component with phantom supply type in the first operation of the subsequent sector assembly bill of material is not allowed. Therefore, the Lot Creation window does not permit you to create the lot based job with phantom supply type material in the first operation.

**Note:** If you defined two components in the first operation, then only one is pushed into this job based on the starting lot selected.



**Starting Lot**

Starting Lot: 01222002      Attributes: [.]

Item: SMC1000      Raw Wafer

Revision: [ ]

Subinventory: Stores      Locator: [ ]

Quantity On Hand: 1000      Available: 1000

**Resulting Lots**

Job Information    Quantity    Planning

Resulting Lot	Assembly	Alternate Routing	Rev	Routing Revision Date	Alternate BOM	[ ]
01222002	SMC2000	[ ]	[ ]	20-AUG-2004 09:30:15	[ ]	[ ]
[ ]	[ ]	[ ]	[ ]	[ ]	[ ]	[ ]
[ ]	[ ]	[ ]	[ ]	[ ]	[ ]	[ ]
[ ]	[ ]	[ ]	[ ]	[ ]	[ ]	[ ]

Lot Attributes    Save

- In the Quantity tab—The Job Quantity for this job is derived based on starting lot quantity available under this lot number, and you can change the job quantity. You can also create multiple jobs for different assemblies and quantities. The application creates multiple jobs and pushes this lot into the jobs. You can also create a job with less than the defaulted quantity. If you create a job using less than the starting lot quantity in the subinventory, then the remaining quantity of the starting lot remains in the subinventory, and you can use this for subsequent job creation. You can also issue a starting component for the quantity more than or less than the component required quantity suggested by the application. In this case, you can enter the required value in the Component Quantity Issued field. In addition, the following information is available in this tab:

- Component usage per assembly
- Component requirement for the job quantity
- Start Job Quantity
- MRP Net

You can change some of these values depending on the transactions performed for this lot.

- In the Planning tab, Start Date and Completion Date values display and can be changed. Choose the Co-Products Supply check box to indicate that resulting lots are used as co-product supply.

If the inventory lot from which the new WIP lot is created, and the new WIP lot have the same attribute context, then lot attributes will be copied to the new WIP lot. If they have different context, then enter lot attributes as follows.

**To view lot attributes for starting lots:**

- Choose Attributes.

If the starting lot contains attributes, then the lot attributes window appears.

2. Choose WMS or INV attributes to view individual segments of the attribute.
3. Choose OK when you are finished viewing the attribute.

**To view, enter, and update lot attributes for the resulting lot:**

1. Navigate to the WIP Lot Transactions window.
2. Choose Lot Attributes.

**Note:** If you are entering or updating lot attributes, then enter and update attributes with appropriate values for WMS and INV attributes based on the lot attributes setup that you or your system administrator have performed. The WMS attributes for the resulting lot are inherited from the starting lot only if the source and resulting lot's assemblies have the same context. In case of a merge transaction, the WMS attributes are inherited from the representative lot of the starting lot. The INV attributes are always inherited from the source lot whether the context of the source and resulting lot is same or not. In case of a merge transaction, the WMS attributes are inherited from the representative lot.

3. Choose OK to save your work and return to the WIP Lot Transactions window, or choose cancel to discard changes.

**Note:** If you are only viewing lot attributes and are not making changes, then you can choose OK or Cancel to return to the WIP Lot Transactions window..

## Kanban Replenishment on Lot Based Jobs

Kanban is a pull based replenishment process in a manufacturing system. You can create lot based and discrete jobs to replenish empty kanbans. In addition, Kanban supports creation of lot based jobs by selecting the starting inventory lot during Kanban replenishment process.

The following are major features of Kanban support on lot-based jobs:

- During Kanban replenishment process, you can choose the starting inventory lot for the item attached to first operation. This is similar to lot-based job creation using the Lot Creation window.
- Use the Honor Kanban Size parameter to create a lot based job quantity equal to kanban size when components are pushed from an inventory lot during kanban replenishment. If this check box is not selected, lot based jobs are created for the maximum number of assemblies which can be built using the selected component lot. If the check box is selected, the application will honor the kanban lot size.

- After a job is created using Kanban replenishment, you can query the Lot Based Job window to view Kanban information.
- If the assembly from replenishment lot based job is completed, then the supply status of a production Kanban is updated to Full.
- Shop Floor Management allows jobs with a Kanban reference to be merged with another job with a different kanban reference (case 1), or a job with a kanban reference with a job without any reference (case 2). In the first case, one of the jobs is the representative lot, for that wip lot the net effect from a kanban standpoint is the same as a quantity update. But for a non-representative lot, the quantity become zero and the corresponding Kanban card status is set to Empty, and the job should not be referenced. In the second case, if the Kanban reference job is the representative lot, then the net effect from a Kanban standpoint is the same as a quantity update for that job. Otherwise, the quantity becomes zero, the corresponding Kanban card status is set to Empty, and the job should not be referenced. See: Defining Kanban Pull Sequences, *Oracle Inventory User's Guide*.

## Lot Based Job Reporting

The following Oracle Work in Process reports support lot based job reporting:

Discrete Job Data Report, *Oracle Work in Process User's Guide*.

Discrete Job Listing Report, *Oracle Work in Process User's Guide*.

Discrete Job Routing Sheet, *Oracle Work in Process User's Guide*.

WIP Accounting Classes Report, *Oracle Work in Process User's Guide*.

WIP Outside Processing Report, *Oracle Work in Process User's Guide*.

Discrete Job Shortage Report, *Oracle Work in Process User's Guide*.

Job lot Composition Report, *Oracle Work in Process User's Guide*.

Discrete Job Value Report, *Oracle Work in Process User's Guide*.

WIP Value Report, *Oracle Work in Process User's Guide*.

## Lot Based Job Component Pick Release

### To run the Lot Based Job Component Pick Release (SRS) report:

1. Navigate to the Lot Based Job Reports window.
2. Select the Lot Based Job Component Pick Release (SRS) report from the Name list of values.

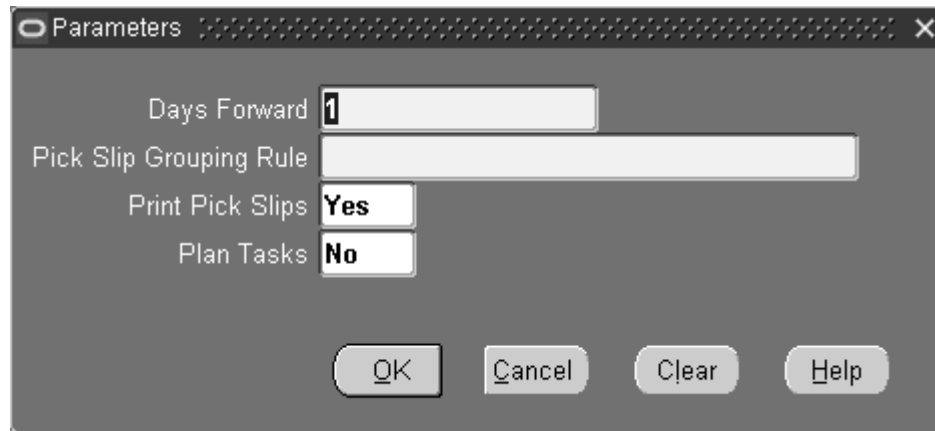

The screenshot shows a 'Parameters' dialog box with the following fields and options:

- Days Forward:** A text input field containing the number '1'.
- Pick Slip Grouping Rule:** A text input field that is currently empty.
- Print Pick Slips:** A dropdown menu with 'Yes' selected.
- Plan Tasks:** A dropdown menu with 'No' selected.

At the bottom of the dialog box, there are four buttons: 'OK', 'Cancel', 'Clear', and 'Help'.

3. Enter Days Forward.
4. Enter the Pick Slip Grouping Rule from the list of values.
5. Optionally, enter Print Pick Slips for the list of values.
6. Optionally, enter Plan Tasks from the list of values.
7. Choose OK.
8. Choose Submit to run the report.

## Pending Transactions Report

If there are pending transactions associated with a lot based job, then the lot based job cannot be closed. You can report on all pending transactions for a given set of jobs and review to take appropriate action before launching the close job program. The close job program provides selection criteria with an option to eliminate jobs with pending transactions. The Pending transaction report can be used during period closing

### To run the Pending Transactions Report:

1. Navigate to the Lot Based Job Reports window.
2. Select the Pending Transactions Report from the Name list of values. The Parameters window appears.

The screenshot shows a 'Parameters' dialog box with the following fields and values:

Class Type	
From Class	
To Class	
From Job	
To Job	
From Job Release Date	
To Job Release Date	
From Job Start Date	
To Job Start Date	
From Job Completion Date	
To Job Completion Date	
Status	Complete - No Charges
Exclude Reserved Jobs	Yes
Exclude Un-Completed Jobs	Yes

Buttons: OK, Cancel, Clear, Help

3. Enter report parameters.
4. Choose OK.
5. Choose Submit to run the report.

## Integration with Outside Processing

Outside Processing enables you to include supplier-sourced components and resources in the manufacturing process. Key features of outside processing for lot based jobs include the following:

### Setup

Setup is needed for Inventory, Bills of Material and Cost Management, Purchasing, and Work in Process. See: *Outside Processing, Oracle Work in Process User's Guide*.

**Requisition Creation Time:** To enable outside processing (OSP), you need to set requisition creation time in the WIP parameters window. In WIP discrete jobs, the At Job and Schedule Release setting creates purchase requisitions for all OSP operations in the routing, while the At Operation setting creates purchase requisitions only when a job reaches the queue of an OSP operation. In Shop Floor Management, you do not know the next operation a priority (i.e. due to network routing and jump transactions), therefore, purchase requisitions are only created at the queue of an outside processing operation. To support this, At Job and Schedule Release and At Operation behave identically for Shop Floor Management. Note: For Manual setting, all purchase requisitions must be created manually. See: *Outside Processing, Oracle Work in Process User's Guide*.

**OSP Resource, Department, Item:** An OSP operation requires one or more OSP resources, which in turn must be associated with departments with a location. In addition, a separate OSP item must be created to receive and charge the outside work (this item is associated with the resource). When creating the OSP item, the Purchasing Tabs of the Item window must have OSP-related settings (i.e. Purchased, Purchasable, Outside Processing Item must be checked.) The list price must be specified in the purchasing master organization for generating purchase orders. See: *Outside Processing, Oracle Work in Process User's Guide*.

**Routing:** To associate an OSP resource with a routing (either directly or using standard operations), you must specify a charge type (either at the resource, the standard operation or the routing level). For Shop Floor Management, charge type PO Receipt should be used for OSP operations. PO Move, which moves any received quantity to the queue of the next operation in WIP discrete jobs, is not supported (i.e. error message appears in jobs with this setting). Withlot based jobs, the next operation is not predetermined and partial receipts should not be moved until the entire quantity is received. See: *Outside Processing, Oracle Work in Process User's Guide*.

## Outside Processing Scenarios

Automatic creation of purchase requisitions generally occurs when a job moves forward to or starts at the queue of an OSP operation (there are exceptions, such as Undo back to an OSP operation queue).

You should expect a warning message at the queue of an OSP operation when performing a transaction that would invalidate one or more purchase requisitions. You should manually cancel or update purchase requisitions for such transactions. Note that these warning messages appear even for purchase requisitions that have not yet been completely processed by the purchasing transaction manager (i.e. are still in purchase requisition interface tables) as well as for purchase orders.

As discussed in routings setup, charge type PO Move is de-supported. You are allowed to create operations in a routing with charge type PO Move, but are not able to start at or move to PO Move OSP operations.

## Job Creation/Update

- **Lot Based Job Creation/Lot Creation:** Starting a job at an OSP results in automatic purchase requisition creation. For the define Lot Based Job and Lot Creation windows, the starting operation, which is always the first operation of the routing, would need to have an OSP resources for this to occur. Creating a lot based job to start at a PO Move OSP operation gives an error and not allow the transaction to be saved (applies for both released and unreleased status).
- **Lot Based Job Update:** Creating a job as unreleased status will not result in purchase requisition creation, but upon changing the status to released, a purchase requisition is created if the starting operation is OSP. Increasing job quantity through the Lot Based Job window at an OSP operation causes a new purchase requisition to be created for the additional quantity. Changing job status from released to unreleased where the first operation is OSP would mean that a purchase requisition should no longer exist and will result in warning.

## WIP Lot Transactions

- **Split/Merge:** Performing WIP lot transactions that have new resulting jobs, such as split or merge, would mean that purchase requisitions or purchase orders for

the starting jobs would need to be cancelled manually. Note that instead of canceling all purchase requisitions or purchase orders for starting jobs and creating new purchase requisitions for resulting jobs, you can keep existing purchase requisitions or purchase orders by updating their distribution. Also note if a purchase requisition, purchase order is kept because a starting job retained quantity and became a resulting job, then the quantity listed on that purchase requisition or purchase order would need to be updated manually.

- **Update Routing/Assembly:** Updating the routing or assembly for a job to start at an OSP results in purchase requisition creation. If you are leaving the queue of an OSP operation, this would imply a purchase requisition is being abandoned in the old routing and would need to be manually cancelled. Attempting to update routing or assembly to start at a PO Move OSP operation will result in an error message and will not save.
- **Update Quantity:** Increasing job quantity through the WIP Lot Transactions window at an OSP operation causes a new purchase requisition to be created for the additional quantity.
- **Bonus:** For a bonus WIP lot transaction, we can start at any operation queue and expect automatic creation of a purchase requisition if an OSP resource is present. Starting a bonus job at any operation which has a resource of charge type PO Move results in an error.

### Move Transactions

- **Move:** Moving a job to the queue of any OSP operation results in the automatic creation of purchase requisitions. Moving to a PO Move OSP operation results in an error. You can move from an OSP operation without formally receiving the OSP item.
- **Jump:** Jumping to the queue of an OSP operation, both inside and outside the routing, results in the creation of a purchase requisition. A jump from an OSP operation queue (with Charge Jump From Queue set to OFF) results in a warning to manually cancel purchase requisitions. Jumping to a PO Move OSP operation results in an error.
- **Undo:** Performing an undo back to an OSP operation queue does not result in purchase requisition creation. An undo at an OSP operation results in a warning, since a purchase requisition may be abandoned.

### Defining Network Routings

A warning is given if an outside processing resource of charge type PO Move is associated with an operation in the Network Routing window.





---

# Resource Scheduling Workbench

This chapter covers the following topics:

- Overview of Resource Scheduling Workbench
- Using the Resource Scheduling Workbench
- Defining User Preferences
- Job Operation Bars
- Navigation
- Viewing Property Windows
- Capacity Exceptions
- Showing Select Resources and Resource Load Versus Capacity Panes
- Selecting a Resource
- Adjusting Resource Capacity
- Rescheduling Jobs, Operations, and Resources in the Gantt Chart
- Rescheduling Start and End Dates
- Resource Transfer
- Transferring Work to an Instance
- Transferring Work Between Instances
- Transferring Work Between Alternate Resources
- Launching the HTML User Interface

## Overview of Resource Scheduling Workbench

The Resource Centric Gantt provides a graphical display of your shop floor by resource, and make it extremely easy for you to visualize the workload on any given resource. By providing a resource centric view, it is easy to pinpoint resource overloads and find bottlenecks on your shop floor.

If you set the WSM: Create Job Level BOM and Routing Copies profile option to Yes (Option 2), then you can view a graphical representation of the released lot based jobs. The workbench displays completed, current, and future operations for all jobs for a particular resource, or set of resources. Color codes represent operation stages.

You can use the workbench to:

- View resource overloads and update resource capacities.
- Update operation start and end dates.
- Change to an alternate resource.
- Assign a resource instance or change to a different resource instance.
- Use the Oracle Shop Floor Management HTML user interface to change recommended paths, or choose substitute components.

If changes are made, then you can reschedule the entire shop floor based on mid-point, forward, or reverse scheduling. The scheduling is based on the infinite scheduling method.

This section includes the following topics:

## Using the Resource Scheduling Workbench

Launch the Resource Scheduling Workbench by navigating to the Resource Scheduling Workbench for Lot Based Jobs window from the Resource Scheduling Workbench menu item in Oracle Shop Floor Management responsibility.

The workbench appears and shows all the jobs in the Navigator hierarchy and Gantt Chart panes.

The navigator on the left side of the workbench displays the resources, and the Gantt Chart pane displays graphical bars that represent the job operation that the resource is used in.

My Resources is the root in the navigator, and contain no resources the first time you open the workbench. The resources that you select and the display order are saved in User Preferences.

If you drill down a level from the resource, then you will see all resource instances for that resource. Person type instances also display under Resources in the navigator. You can assign the same person to multiple resources.

The Resource in the navigator is a combination of the resource and owning department, and any instances under that resource belong to the department.

The bars in the timeline represent the job operations where the resource is being used. The duration of the bar depicts the start and end times of the resource used in that job operation.

- Each job and operation bar has a label that represents the job, operation, and department where the resource is used. You can customize labels in the Preferences window.
- If a resource is used in multiple job and operations, and those job and operations overlap, then the bars overlap in a cascading pattern.
- The current operation of a lot-based job displays in a different color.

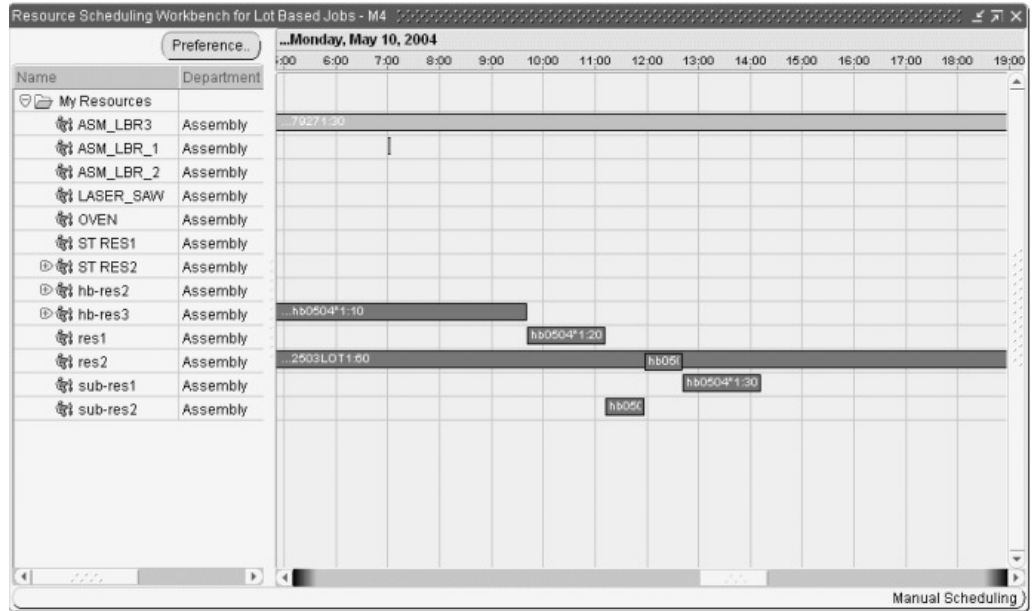

## Defining User Preferences

The user preferences let you select the resources to initially display in the Gantt chart. The resources in the unselected list display in a navigator by department, with the resources that the department owns being the second level in the navigator.

### To define user preferences:

1. Navigate to the Resource Scheduling Workbench for Lot Based Jobs window.
2. Choose Preference to select resources for displaying in the workbench.
3. Select resources you want to view in the Unselected region and move them to the My Resources region.

When the resource you select is moved to the My Resources region, the workbench displays the resource name followed by the owning department. The order in which resources display in the navigator are determined by the order in the My Resources region. If you select the Department category in the Unselected region and move it to the My Resources region, then all resources for that department will be included in the My Resources region.

You can change the display order of the resources by selecting the resource in the My Resources region and using the arrows to move the resources. Any resources that remain in the Unselected list will not display in the workbench.

4. Enter the Default Scale at Startup value.
5. Enter the default Row Height.
6. Select the Bar Text. You can display the assembly name or the job name.
7. Select the Lot Based Job Status values to display on the gantt chart. Only the Job Status values selected will display on the gantt.
8. Choose the Make Changes Permanent indicator to save the changes to the My Resources region when choosing OK.

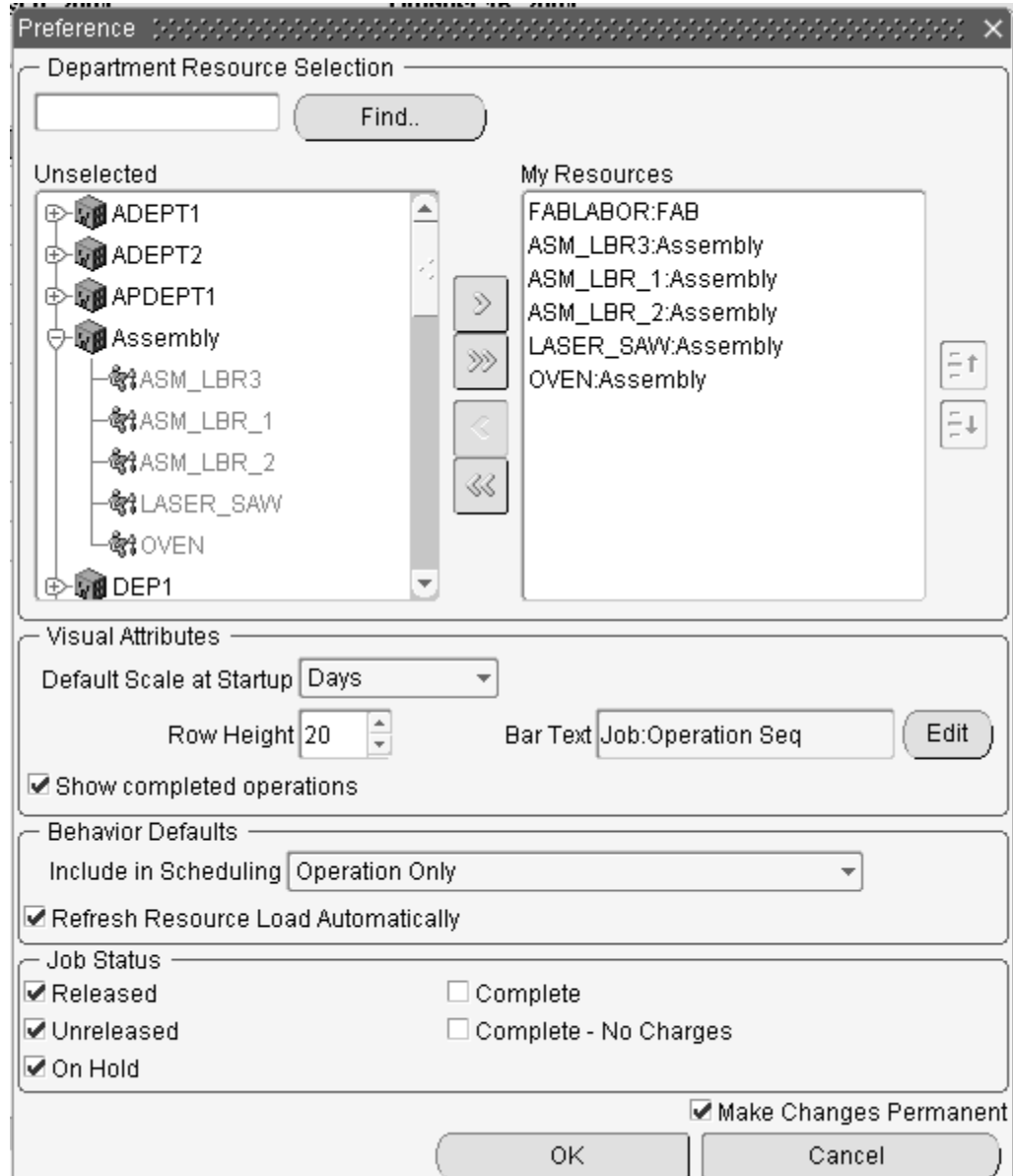

## Job Operation Bars

The bars in the timeline represent the job operations where the resource is being used. The duration of the bar represents the start and end times of the resource used in that job operation.

- Each job and operation contain a label that represents the job, operation, and department where the resource is being used.
- If a resource is used in multiple job and operations, and those job and operations overlap, then the bars overlap and display in a cascading pattern.
- The current operation of a lot-based job displays in a different color.

## Instance

Instances are shown beneath the resource node in the navigator.

- Job Operations assigned to a specific instance display on the timeline at the instance level.
- Job Operations that are not assigned to a specific instance display at the resource level.

## Batchable Resources

The job operations where batchable resources are used overlap.

## Alternate Resources

Alternate Resources display on the navigator and timeline.

## Setup Time

Setup time for the resource displays as a separate bar from the job operation bar. The color of the bar for setup time displays as a different color from the job operation bar.

## Bar Color

The color scheme for operations are:

- Grey: completed operations
- Blue: current and future operations
- Red: current operation deleted from path

## Navigation

### Job Operation

If you position the cursor over a job operation, then that job operation bar is selected. If you keep the cursor over the bar, a tool tip appears, giving details about the job operation.

### Simultaneous and Batched Resources

If you position the cursor over a job operation that contains a simultaneous resource, then any other corresponding simultaneous job operation resources are selected. Similarly, if you place the cursor over a job/operation for a batched resource, then all other job/operations in that batch will also be selected.

### Progress Indicator Bars

The bars in the gantt chart contain a progress indicator. Since a lot-based job does not have partial completion, this indicator displays either 0% or 100%. This displays separate completed operations from those not completed.

### Selecting Overlapped Bars

If you select a bar that is in a group of overlapping bars, then that bar appears at the top of the group. The vertical position of the bar will not change, and the bar will remain on top as long as the mouse button is pressed. Once the mouse button is released the bar will return back to its original position.

## Viewing Property Windows

Property windows for jobs, operations, or resources are available in the Gantt Chart pane. These windows contain information about dates, quantities, descriptions of the scheduling data. See: Job Properties Window, Operation Properties Window, and Resource Properties Window.

### To view a property window

- Right click on a job, operation, or resource in the navigator hierarchy or Gantt Chart pane.
- Right click on a job, operation, or resource.

A drop-down menu appears.

Choose Properties. The property window for the respective job, operation, or resource displays.

bus1:30	
General	
Operation Code	FOS3
Operation	30
Resource Seq	10
Department	FAB
Lot Based Job	bus1
Job Description	
Assembly	SMC2400
Assembly Description	Processed Wafer
Requested Job Start Date	
Requested Job Due Date	
Firm	No
Utilization	100.0%
Efficiency	100.0%
Usage Rate Or Amount	100.0
UOM	HR
Basis	Item
Assigned Units	1.0
Required Resource Units	500.0
Adjusted Resource Time	500.0
Touch Time	500.0
Resource Start Date	27-JUL-2004 16:18:00
Resource End Date	19-OCT-2004 20:17:51
Setup	
Batch	
Batch Load	

## Job View

Right click on an operation resource bar, select menu "View Job Information" and a job view will appear on the bottom of the window.

## Job Operation Property

Right click on the operation in "Job View" area, select menu "Properties", a property window for the job operation will show up.

## Load Graph

A load graph will be available to display at the bottom of the window. You would be able to toggle the display of the load graph on/off, by pressing the load graph icon on the toolbar.

You will be able to select the resources to display on the Load Graph, by clicking the Select Resource(s) button. The name of the resources that you selected would then be displayed for each row on the load graph. The resources you select are the department resources, and will be displayed as the resource name followed by the owning department.

In addition to viewing the load graph and then selecting resources via the Select Resource(s) button, you will also be able to view the load for a resource by right clicking it in the tree. By right clicking the resource in the tree a popup menu will appear, and from there you may pick the View Resource Load option. Choosing that option will automatically display the load graph (if it isn't already displayed) and will show the load for the resource.

## Capacity Exceptions

You can define capacity exceptions by right clicking on the resource (or instance) in the workbench, or by right clicking on the resource (or instance) in the load graph region. Choosing Change Capacity displays the Capacity Change window.

### Reason Codes

When defining a capacity exception, you can define an exception a reason. Navigate to the Resource Capacity Change Reasons window to define reason codes. You can apply reason codes to the capacity changes when defining exceptions in the Bills of Material window or in the workbench.

The pre-seeded Reason codes include:

- Breakdown
- Scheduled Maintenance
- Plant Shutdown
- In training
- Not available

### Displaying Resource Unavailable Time

If a capacity exception brings the availability for the resource to zero, then capacity exceptions for a resource display on the timeline. The exception displays as a shaded region on the timeline and is the same color for displaying weekends.

Capacity exceptions display at both the resource and resource instance level.

## Showing Select Resources and Resource Load Versus Capacity Panes

The Resource Scheduling Workbench lets you show or hide job operations from the resources listed, and the resources in relationship to the capacity available. You can identify problems for analysis so that tasks can be modified. For example, the order



in which the resource performs these tasks or the shifting the tasks across the other resources.

### **To show the Select Resources and Resource Load Versus Capacity Panes**

- Choose the Resource Load indicator from the View menu.
- Choose Show/Hide Resource Load from the toolbar.

The Select Resources and Resource Load Versus Capacity panes appear.

### **To hide the Select Resources and Resource Load Versus Capacity Panes**

- Choose the Resource Load indicator again from the View menu.
- Choose Show/Hide Resource again from the View menu or toolbar.

The Select Resources and Resource Load Versus Capacity panes do not appear.

## **Selecting a Resource**

You can select a specific resource. If you are uncertain of the resource name, expand a job and an operation and view the specific resource of interest. Select a resource bar with your mouse pointer (yellow text bubble appears which indicates the name of the resource). The name of the resource is also available on the Resource Properties window.

### **To select a resource:**

1. In the Select Resource(s) pane choose the Select Resources button.

The Select Resource(s) window appears.

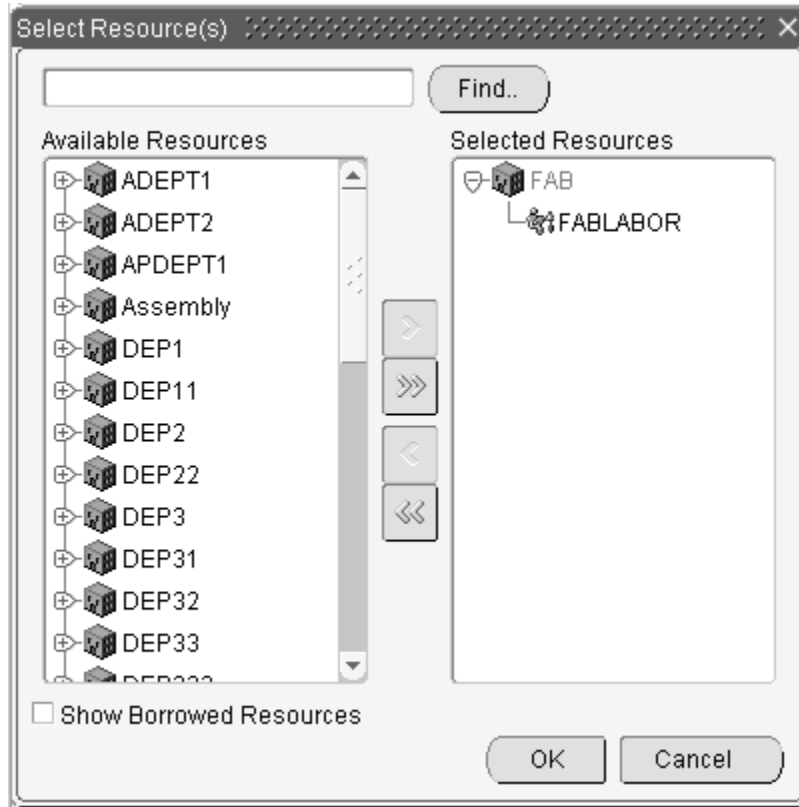

2. In the Available Resources pane select a resource or an instance.
3. Choose the right arrow button.
4. Choose OK.

The resource appears in the Selected Resources pane.

The name and description of the resource appears in the Select Resources pane and its corresponding graphic display for the resource appears in the Resource Load Versus Capacity pane. This represents the resource load for all jobs on the shop floor requiring this resource. The default graphic view is Table. The Required and Available key indicators appear.

5. From the graphic drop-down menu choose Continuous.

A continuous line graph appears. The Required, Available, and Overload key indicators appear.

6. From the graphic drop-down menu choose Bar.

A bar graph appears. The Required and Available key indicators appear.

## Adjusting Resource Capacity

You can adjust resource capacity to respond to machine or personnel availability. This includes:

- Delete or add a day of capacity, adjusting for overtime shifts or shop closures

- Add or delete resource units when either extra resources are obtainable or resources are unavailable
- Adjust Assigned Units or Usage Rate for the resource on the job routing

Simulation sets are used to link resource changes for scheduling. Simulation sets are defined, associated to resources in Oracle Bills of Material, and linked to Work in Process scheduling in Work in Process Parameters window.

There are two methods for adjusting resource capacity:

1. Navigate to the Departments window in Oracle Bills of Material, and from there access the Resources, Shifts, and Capacity Changes windows.
2. Access the Capacity Changes window directly from the Resource Scheduling Workbench.

### To adjust resource capacity through Bill of Materials:

1. Navigate to the Departments window from Oracle Bills of Materials.
2. Choose Resources to navigate to the Resources window.
3. Select a resource, then choose Shifts.

The Shifts window displays. This window is used to assign shifts to the resource from those assigned to the workday calendar.

4. Select a shift and choose Capacity Changes to define capacity changes for a shift.

The Capacity Changes window displays. Capacity modifications include adding or deleting days.

5. Select the designated simulation set defined on the Work in Process Parameters window.
6. Save your work.
7. In the Resource Scheduling Workbench, select Refresh Resource Load from the View menu to display your changes.
8. Select Schedule Multiple Work Orders to apply these capacity adjustments to the shop floor schedule.
9. Select Schedule Multiple Work Orders to apply these capacity adjustments to the shop floor schedule.

**Note:** If you select an alternate resource, make changes to the current operation, and save the job in the workbench, then changes do not display in the html based User Interface. The application stores changes made to the current operation in the WIP tables, not Shop Floor Management copy tables. Shop Floor copy tables store information from the last APS and Infinite Scheduler manual change.

### To adjust directly from the Scheduler Workbench:

Select Resource Load from the View menu or toolbar to display the Resource Load versus Capacity pane.

1. Choose Resources in the Select Resource(s) pane.

If the resource is scheduled by instance, and you want to adjust capacity, then select the instance in the Available Resource(s) pane. If you select the resource and not the instance, then the only action you can perform is deleting a day.

2. When the resources display on the workbench, select and right-click on the resource you want to adjust.

A drop-down menu appears.

3. Choose Change Capacity. The Capacity Changes window displays. A resource must be assigned to a department and a shift to display this window.

The Resource and Department fields display the resource name and the department it is assigned. The Simulation Set field displays the simulation set used to link resource changes to available resource capacity.

The Schedule by Instance field displays Yes or No depending on whether the resource has specified instances (machine or labor type). This is set on the Resources window, the Schedule by Instance indicator.

In the Capacity Changes region of the window, you can change or add information depending on the resource definition.

If you selected a resource scheduled by instance, then the only available value in the Action field is Delete a Day. For these resources, access the instance to adjust capacity.

4. In the Shift field, select available shifts from the list of values.

Shifts are defined on the Shifts window when you are assigning a resource to a department.

5. Select the action you want to perform. The choices are Add Capacity, Delete a Day, Reduce Capacity, or Add a Day.

You can only delete work days, and only add non-work days.

6. If you are adding or reducing capacity, select the capacity units you want to change.

The value in the Units field is defaulted from the assigned units of the resource to this department, and can be changed.

7. In the Date fields, From and To, select the dates for this capacity action to occur.

8. In the Time fields, From and To, the values default from the shift information, but can be changed.

9. Save your work.

10. Select Refresh Resource Load to display your changes.

## Rescheduling Jobs, Operations, and Resources in the Gantt Chart

You can manually reschedule the start and end dates of a job, operation, or resource:

- Grab and drag the start or end of a bar
- Use the Edit Schedule window

You can invoke the Bar Inspector window that shows the start and end dates of a selected job, operation, or resource.

## Rescheduling Start and End Dates

You can manually reschedule any job, operation, or resource without regard for constraints or scheduling rules.

### To manually forward or backward reschedule using the pointer:

1. Point at the start or end of a job, operation, or resource bar.
2. Click and drag to the right (forward) or left (backward).
3. The beginning or end of the bar moves to the right or left, respectively.
4. Save your work.

### To manually forward or backward reschedule using the editor

5. Right click on any bar.  
A drop-down menu appears.
6. Choose Edit Schedule.  
The Edit Schedule window appears.
7. In the Start Date and/or End Date fields, enter the new start and/or end date for the required job or operation.
8. Choose Apply.  
The bar moves to the new start and/or end date.
9. Save your work.

## Modifying Times

You can only change or reschedule a job operation in terms of time by dragging the bar. You cannot alter the duration (width) of the bar.

You can use the snap to feature to align when dragging. This feature helps to eliminate small gaps between operations that may be too small to visually see on the gantt chart.

### To use the Snap To feature:

Right click on the job operation bar that you wish to move. A menu will appear.

10. Choose Snap To from the menu
11. Choose Snap Left or Snap Right. Snapping left aligns the starting time of your job operation to the next closest start or end time of another job operation. Snapping right aligns the ending time of your job operation to the next closest starting or ending time of the nearest job operation.

The behavior of rescheduling a job operation varies with the type of resources the job operation uses.

## Single Resource

A single resource refers to a resource that is not batched or simultaneous.

## To reschedule a job operation using single resources:

1. Click and drag the job operation bar. When you release the bar, a small window appears and displays scheduling information.
2. Choose Schedule to schedule around the job operation resource bar that you dragged. Choose Cancel if you don't want to perform the change. Choosing Cancel will close the window, and move the bar back to its original location
3. Choose Schedule to schedule the job. The job is scheduled according to the following rules:
  - The job operation resource or operation resource instance you dragged is locked at the location you dragged it to, and the application schedules any prior or future operation resources around it.
  - The job is midpoint forward scheduled from the starting date of the job operation resource that you dragged.
  - The application backward schedules any prior operations.

## To schedule reschedule a job operation using simultaneous resources:

Simultaneous resources are those resources that are performing at the same time as another resource, and will occur within the same job operation of a given job.

1. Select the job operation you wish to modify and drag the bar.

If you are dragging the job operation, then other instances of the same job operation containing a simultaneous resource will first remain at the original location, but will move the same amount as the operation you are dragging when you release the mouse.
2. Release the bar. Scheduling in this scenario is similar to using a single resource. When using simultaneous resources, scheduling considers multiple job operation resources.

## Rescheduling Instances

Dragging (changing time) of a job operation bar at the instance level will be similar to the other procedures. There are a couple of things to note, however, and these are listed below:

- If the job operation you are dragging is spread across several instances, we will still only show the one job operation bar move as you drag, but the scheduler will move the other instances accordingly once it completes.
- We will never re-dispatch the job operation to other instances.

## Resource Transfer

Using the Resource Centric Gantt, you can transfer work from one resource to another. There are three types of transfers that can occur:

- transferring work to an instance
- transferring work between instances
- alternating resources.

## Transferring Work to an Instance

Transferring work to an instance involves moving the job operation from the resource level node to an instance node. By performing this action, you are taking a job operation that was previously unassigned, and assigning it to an instance.

### To transfer work to an instance:

1. Select a job operation resource to transfer to an instance and drag the bar vertically to the instance you want to assign it to.

The following conditions exist while dragging to the instance:

- You can only drag in the vertical direction and cannot change the job operation time.
    - If there is work scheduled at the instance you are dragging to, then you can drag and drop the bar there.
    - If you are dragging a resource that has more than one assigned unit, then the application distributes the units between the instances when you execute the assignment. If a resource has two assigned units after you execute the drag to a resource instance, then the application assigns the other assigned unit to any other remaining instance. This behavior also applies to person type instances.
2. Choose Schedule.

## Transferring Work Between Instances

### To transfer work between instances:

1. Select the job operation for the instance you want to transfer from, and drag the bar to the instance to transfer to.

The conditions for dragging between instances are as follows:

- You can only drag in the vertical direction and cannot change the time of the operation.
    - If there is work scheduled at the instance you are dragging to, then you can drag and drop the bar there.
2. Choose Schedule.

## Transferring Work Between Alternate Resources

Transferring work to an alternate resource may be done at both the resource level and instance level. If you assign a job operation that is associated with a particular instance to an alternate, then the job operation will be assigned at the resource level on the alternate (ie. It will no longer be associated with an instance).

### To transfer work to an alternate resource:

1. Right click on the job operation bar that to assign. The Alternate Resource window appears.

2. Choose Alternate
3. Choose Schedule.

When you choose Schedule, the scheduler executes, and when the scheduling is complete, a dialog displays any exceptions, if any.

## Launching the HTML User Interface

### To launch the HTML User Interface:

1. Navigate to the Resource Scheduling Workbench.
2. Right click a job or operation bar in the Gantt Chart region.
3. Select View Job Information from the drop down menu. The Job Information region displays a new graphical region at the bottom of the Gantt Chart region that displays the job information.

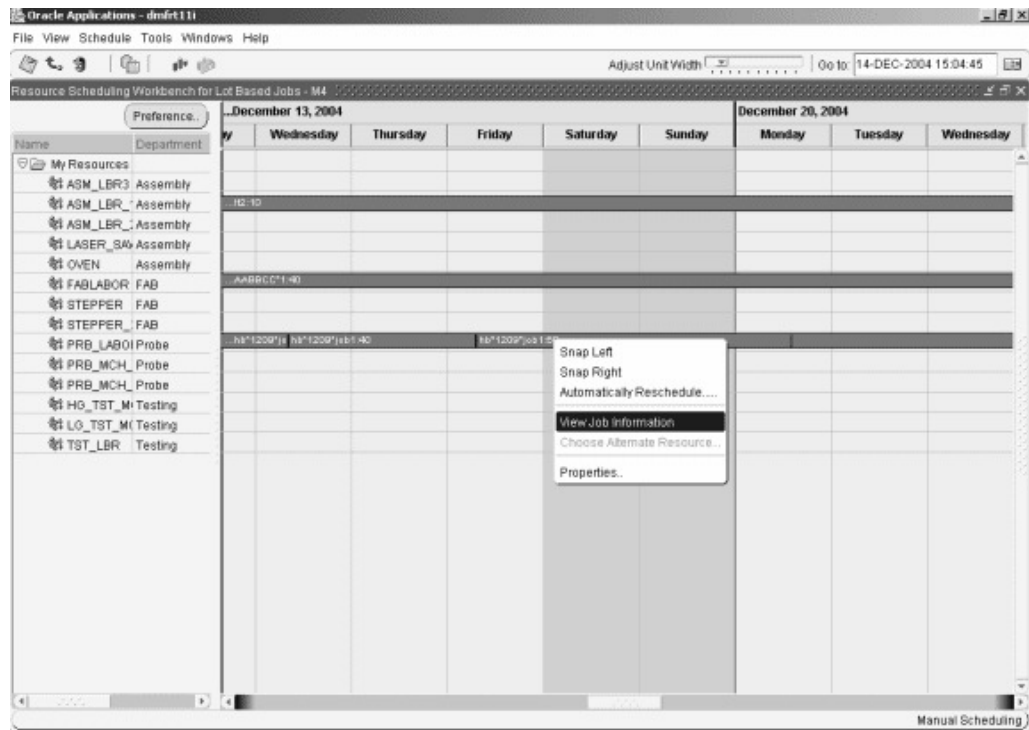

4. Right click a job bar in the Job Information region.



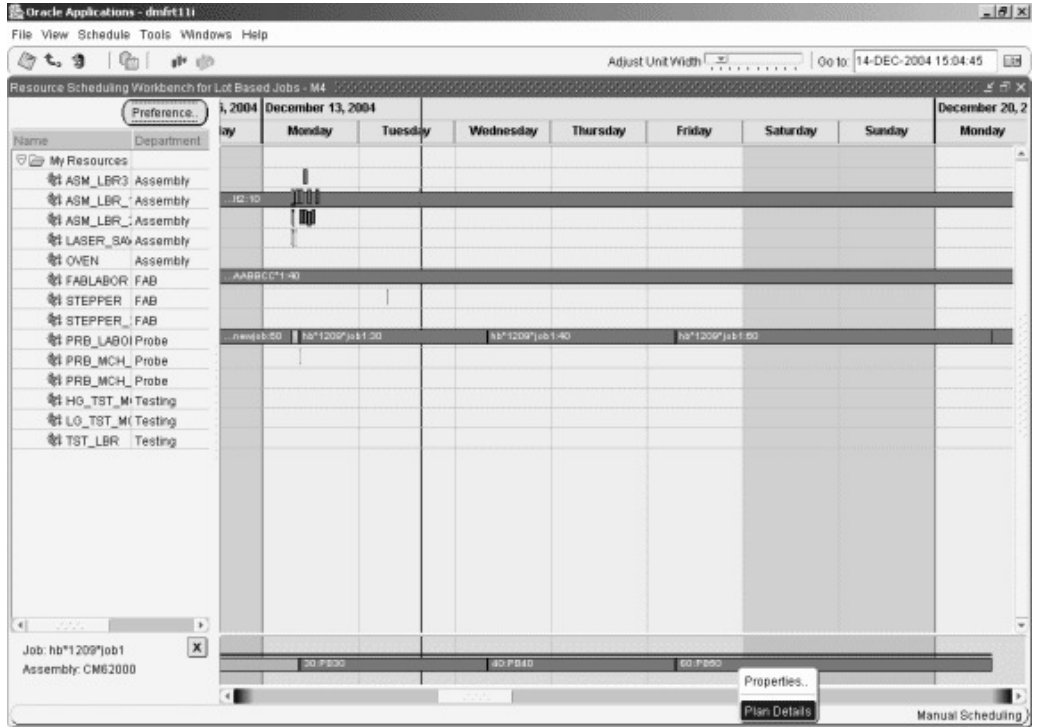

5. Select Plan Details from the drop-down menu. The Plan Details html window appears and displays the plan details of the job. You can make changes to the lot-based job from the Plan Details html window.

See: Integration with Oracle Advanced Supply Chain Planning (ASCP), page 4-13 for using the html UI for changing plan information on the lot based job.

Plan Details: hb\*1209\*job1 - Microsoft Internet Explorer

Address: http://ap61396.us.oracle.com:8012/OA\_HTML/RF.jsp?function\_id=10239740resp\_id=224350resp\_aspl\_id=4106security\_group\_id=00lang\_code=USparams=FM,qB76

**ORACLE** [Diagnostics](#) [Close Window](#) [Preferences](#)

Plan Details: hb\*1209\*job1

Job Description		Quantity Remaining	<b>1500</b>
Assembly	<b>CM62000</b>	UOM	<b>Ea</b>
Assembly Description	<b>Die</b>	Coproducts Supply	<b>Yes</b>
Released Date	<b>09-Dec-2004 17:05:10</b>	Current Routing Operation Sequence	<b>30</b>
Scheduled Start Date	<b>10-Dec-2004 07:00:00</b>	Current Operation Code	<b>PB30</b>
Scheduled Completion Date	<b>20-Dec-2004 14:00:07</b>	Current Operation Department	<b>Probe</b>
Requested Due Date		Routing Refresh Date	<b>09-Dec-2004 17:05:10</b>

[Show Additional Details](#)

Operations

View:

Routing Operation Sequence	Code	Department	Operation Description	Start Date	Completion Date	Scheduled Quantity	Yield	Details
10	PB10	Probe	Load Probe Machine	10-Dec-2004 07:00:00	13-Dec-2004 09:00:00	1000	1	
20	PB20	Probe	Probe Machine	13-Dec-2004 09:00:00	13-Dec-2004 09:00:07	1000	1	
30	PB30	Probe	Unload Probe Machine	13-Dec-2004 09:00:07	14-Dec-2004 11:00:07	1000	1	
40	PB40	Probe	Review Probe Results	15-Dec-2004 08:00:07	17-Dec-2004 07:00:07	1500	1	
60	PB60	Probe	Disposition Probe	17-Dec-2004 07:00:07	20-Dec-2004 14:00:07	1500	1	

[Diagnostics](#) | [Close Window](#) | [Preferences](#)

Copyright 2000-2004 Oracle Corporation. All rights reserved. [About This Page](#) [Privacy Statement](#)

---

## Lot Genealogy

This chapter covers the following topics:

- Overview of Lot Genealogy
- Displaying Genealogy and Where-Used Views

### Overview of Lot Genealogy

Using Lot genealogy, you can view the historical production information of a lot. It provides you with detailed information about where the lot has moved, subinventory stocking points, lot transaction types, and forward and backward tracking. You can view information regarding inventory and WIP lots such as splits, merges, issues, and completions as they progress on the shop floor. The Lot Genealogy window shows how a WIP lot becomes an Inventory lot and vice versa. Lot Genealogy provides you with the ability to do the following:

- View the record of the products created by the lot's transactions
- View all the components used in the lot transactions
- Display detailed information about Inventory and WIP lots created
- See the lineage of where the lot was used

The following graphic displays the historical production of a lot. It shows the detailed information a lot moves through to become a finished good.

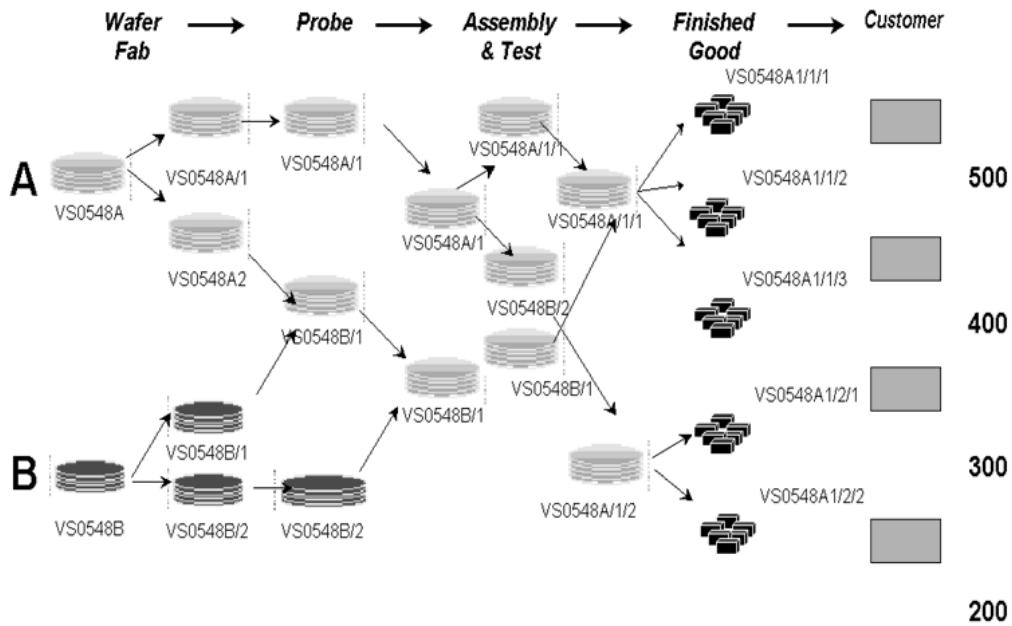

## Displaying Genealogy and Where-Used Views

You can view historical information for lot-based jobs in the Lot Genealogy window. This graphical interface provides an integrated view of genealogy information for discrete jobs, lot-based jobs, and Oracle Warehouse Management inventory transactions. You can view both material and lot-based job transaction information.

### To view lot based job transaction genealogy:

1. Select Genealogy from the menu.
2. When the Find Lots/Jobs window appears, select the Jobs indicator.

The screenshot shows the 'Find Lots/Jobs (M4)' window. The 'Jobs' radio button is selected. The window contains the following fields and controls:

- Inventory Lots
- Jobs
- Jobs: [Text Field] - [Text Field]
- Assembly: [Text Field]
- Description: [Text Field]
- Status: [Dropdown Menu]
- Start Dates: [Text Field] [Text Field]
- Completion Dates: [Text Field] [Text Field]
- Attributes: [Text Field]
- [Clear] [Find]

3. Enter your search criteria.

You can query by Jobs, Assembly, job Status, a range of Start Dates, a range of Completion Dates, and Attributes. You can combine or omit criteria as required.

4. Choose Find.

The Jobs Summary window appears with the records that meet your criteria, and displays job Name, Status, Assembly, and Start and Completion dates.

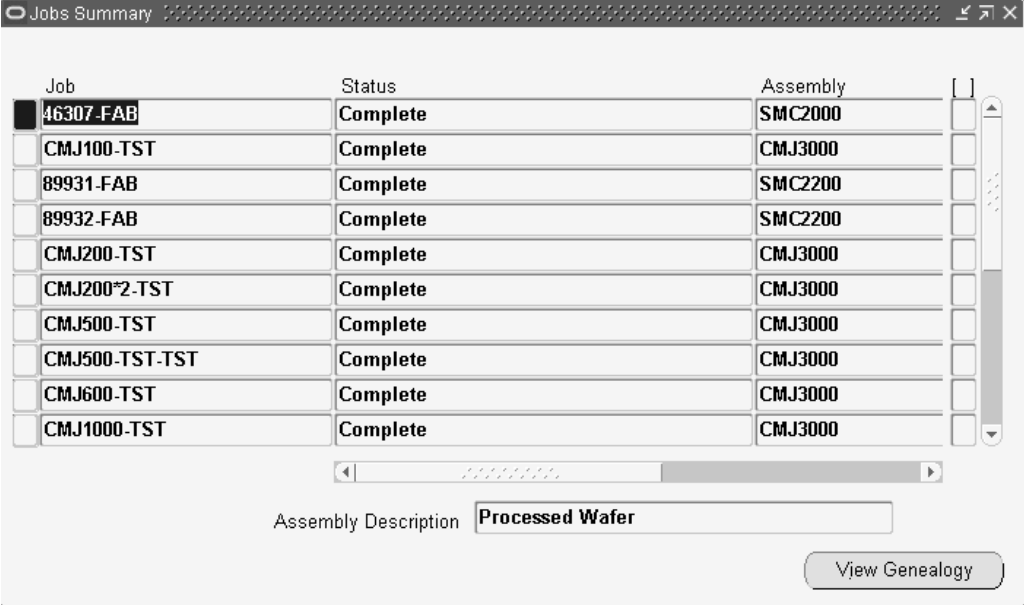

The screenshot shows a window titled "Jobs Summary" with a table of job records. The table has three columns: Job, Status, and Assembly. The first row is highlighted. Below the table is a scroll bar and a text field labeled "Assembly Description" containing the text "Processed Wafer". A "View Genealogy" button is located at the bottom right of the window.

Job	Status	Assembly
46307-FAB	Complete	SMC2000
CMJ100-TST	Complete	CMJ3000
89931-FAB	Complete	SMC2200
89932-FAB	Complete	SMC2200
CMJ200-TST	Complete	CMJ3000
CMJ200*2-TST	Complete	CMJ3000
CMJ500-TST	Complete	CMJ3000
CMJ500-TST-TST	Complete	CMJ3000
CMJ600-TST	Complete	CMJ3000
CMJ1000-TST	Complete	CMJ3000

5. Select a record and choose View Genealogy.

The Lot Genealogy window displays. The left pane is in a Navigator hierarchy format containing two tabs for different views. The right pane displays job detail and transaction information.

6. Select the Lot Source or Where Used tab in the left pane to view genealogy information.

Lot Source displays the source of the record you are viewing. It is designated by assembly name, appended by the job name at the top node of the navigator. For example, you may be producing a specific job from components of a particular lot. Material used in this assembly and job combination is expanded under the top node.

Where Used displays the assembly using this material. It is designated by assembly name, appended by the job name at the top node of the tree. The assembly and job combinations using this top record expand below it.

When you select the Where Used view, information is listed in order of oldest to current, from top to bottom of the navigator. The first record of the query is the parent lot, and the records following are the children and grandchildren of this lot.

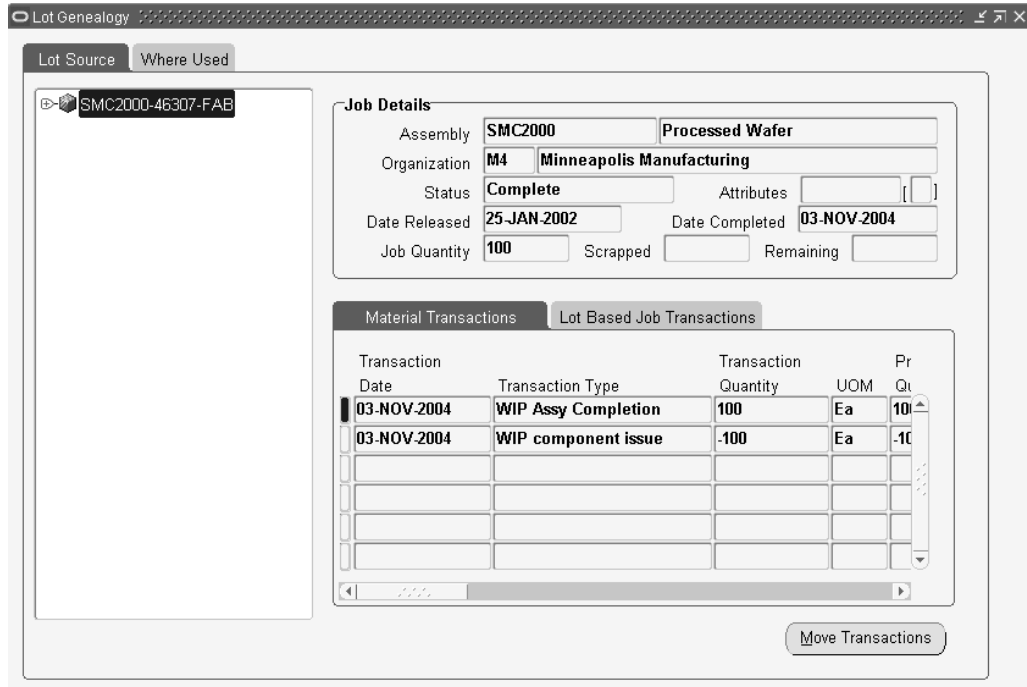

- In the right pane, information about the job displays in the Job Details region. Select the Material Transactions or Lot Based Job Transactions tab to view shop floor work performed.

The Material Transactions tab displays historical transaction information for the record selected on the hierarchical tree. This pane displays the transaction date, transaction type such as component issues or assembly completions, quantity, and item number.

The Lot Based Job Transactions tab displays the Oracle Shop Floor Management transactions such as splitting, merging, bonus lots, and updating assemblies. It displays the previous values for WIP Lot Name, Start Quantity, and Assembly number—and the resulting values after the transaction.

- Choose Move Transactions to access the View Move Transactions window. See: Viewing Move Transactions, Oracle Work in Process User's Guide.

If a job contains no move transactions, then a message appears stating that this job has no move transactions, or the transactions for this job have been purged.

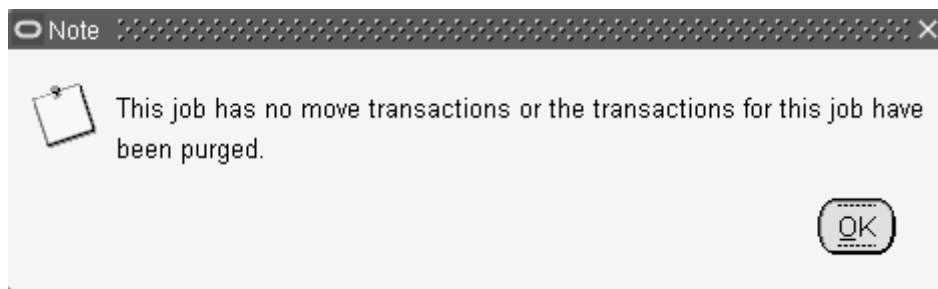

9. If move transactions exist, then the View Move Transactions window appears, and you can view move transaction details.
10. The View Move Transactions window contains the following three tabs that you can choose.
  - Job or Schedule Header
    - Operations, Quantities
    - Scrap, Comments

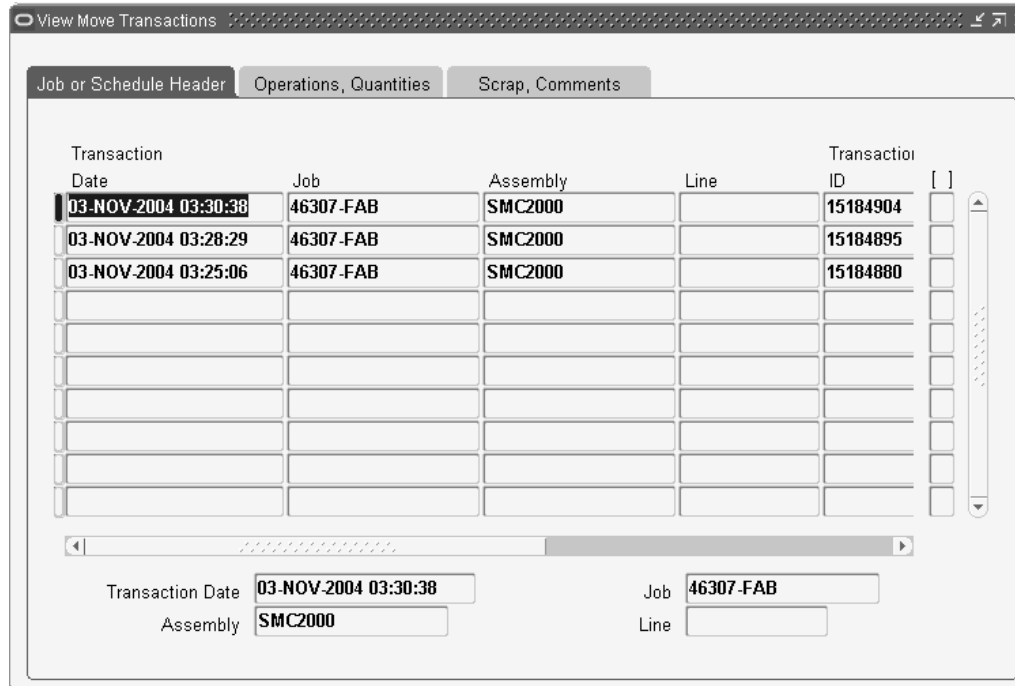

View Move Transactions

Job or Schedule Header   Operations, Quantities   Scrap, Comments

From Operation   To Operation

Seq	Code	Department	Step	Seq	Code	Department	Step	[ ]
<b>10019</b>	FB25	FAB	To move	10029	FB30	FAB	To move	
10009	FB20	FAB	To move	10019	FB25	FAB	To move	
10	FB10	FAB	Queue	10009	FB20	FAB	To move	

Transaction Date: 03-NOV-2004 03:30:38   Job: 46307-FAB  
 Assembly: SMC2000   Line:

View Move Transactions

Job or Schedule Header   Operations, Quantities   Scrap, Comments

Scrap Account	Reason	Reference	[ ]
<b>01-514-5240-0000-000</b>			

Transaction Date: 03-NOV-2004 03:30:38   Job: 46307-FAB  
 Assembly: SMC2000   Line:

11. Close the windows when finished.



---

## Co-Products

This chapter covers the following topics:

- Overview of Co-Products
- Defining Co-Products
- Define Time Phased Split Percentages Window
- Substitute Components Window
- Component Details Window

### Overview of Co-Products

Co-products are assemblies or products belonging to the same product family, and manufactured from the same primary component. When you define co-products, you specify the assemblies, their planning percentages, and the primary component. One of the assemblies is the primary co-product and the others are the non-primary co-products. When you define the co-product group, corresponding bill of materials are created using both the primary bill of material and non-primary bill (or common bill) components. When you create co-products:

- Define an item as the primary component of several end items.
- Define the expected distribution across all the end items. When you create this information in the Define Co-Products window, the Bills of Material of the end items are automatically created.
- Associate a rank and a distribution percentage for the co-products.

Oracle Shop Floor Management is integrated with Oracle Planning enabling you to perform transactions such as implementing planned orders as lot based jobs and rescheduling existing lot based jobs from the Planner's Workbench.

### Defining Co-Products

#### To define Co-products:

1. Navigate to the Define Co-Products window.  
You can query an existing co-product relationship using the search criteria.
2. If you are searching for an existing co-product, choose Find and enter your search criteria.

- If you are creating a new co-product, choose New from the File menu.
- Select an item number in the Component field.  
The assembly's description and, if existing, alternate designator displays.
- In the Usage region, enter data in to the Value and Inverse fields to define the quantity used.

Value is the quantity of the component needed to create the assembly, that is, the quantity of the component needed for each of the co-products. The Inverse is automatically calculated. It is an inverse quantity, one quantity of the component will make that quantity of the co-product.

- In the Effectivity Dates region, enter values From and To if this component is to be disabled at a future date.

Optionally, you can enter data to define an alternate or substitute component. See: Substitute Components Window, page 7- 5 .

Define Co-products (M4)

Component  [ ]

Component Description

**Usage**

Value

Inverse

**Effective Dates**

From

To

**Co-Products**

Co-Product	Rev	Primary	Alternate Bill	Co-Product Description
<input checked="" type="checkbox"/> CM62000	0	<input checked="" type="checkbox"/>	ALT	Die
<input type="checkbox"/> CM62001	0	<input type="checkbox"/>	ALT	Die High Grade
<input type="checkbox"/> CM62002	0	<input type="checkbox"/>	ALT	Die Low Grade
<input type="checkbox"/>		<input type="checkbox"/>		
<input type="checkbox"/>		<input type="checkbox"/>		

- You can view information in the Component Details window.  
This window enables you to view Bill of Material information for the component. See: Component Details Window, page 7- 5 , .
- In the Co-Products region, enter the Co-Product item name in the Co-Product field.  
The item number's Revision level and Engineering Change Number displays.
- If this is the primary co-product, then choose the Primary check box.  
There should be only one primary co-product for a component. Non primary co-products are set up as common bills of material with the primary co-product's bill designated as the common bill. The primary co-product's bill may be an alternate or a primary bill.

10. Save your work.

The completed transaction creates a BOM for each of the co-products entered with the main item in the components header zone as the component.

When committed, you can enter split percentages for the co-products in the Define Time Phased Split Percentages window. By default, 100% is populated for the primary co-product and 0% for the secondary co-products. The user can move to the split percentages zone by pressing the Split Percentage button.

## Define Time Phased Split Percentages Window

Use this window to update co-product split percentages, or add split effectivity date range information.

In the manufacturing process, output of the final product can improve with time. For example, in the semiconductor industry, the quality of a wafer can improve during its life cycle. Early in the life cycle, the same component wafer may produce a lower percentage of high performance chips. Late in the life cycle, the same component item may produce a much higher percentage of high performance chips. You can model this process by providing different sets of planning percentages for resulting co-products from the same component over specific time periods.

### To enter time phased co-products split percentages:

1. From the Define Co-products window, choose Split Percentage. The Define Time Phased Split Percentages window appears.
2. Enter the Split Effectivity From date.
3. Enter the Split Effectivity To date.
4. Save the split percentages for a given range before entering percentages for a new range.

Define Time Phased Split Percentages (M4)

Component

**Split Effectivity Dates**

From	To
<input type="text" value="18-NOV-2004 13:22:00"/>	<input type="text" value=""/>
<input type="text" value="18-NOV-2004 13:26:36"/>	<input type="text" value="19-NOV-2004 00:00:00"/>
<input type="text" value="18-NOV-2004 13:27:37"/>	<input type="text" value="22-NOV-2004 00:00:00"/>
<input type="text" value="25-NOV-2004 13:27:53"/>	<input type="text" value="26-NOV-2004 00:00:00"/>
<input type="text" value="18-NOV-2004 13:28:27"/>	<input type="text" value=""/>

**Split Percentages**

Co-Product	Rev	Primary	Split (%)	Description
<input type="text" value="CM62000"/>	<input type="text" value="0"/>	<input checked="" type="checkbox"/>	<input type="text" value="100"/>	<input type="text" value="Die"/>
<input type="text" value="CM62001"/>	<input type="text" value="0"/>	<input type="checkbox"/>	<input type="text" value="0"/>	<input type="text" value="Die High Grade"/>
<input type="text" value="CM62002"/>	<input type="text" value="0"/>	<input type="checkbox"/>	<input type="text" value="0"/>	<input type="text" value="Die Low Grade"/>
<input type="text" value=""/>	<input type="text" value=""/>	<input type="checkbox"/>	<input type="text" value=""/>	<input type="text" value=""/>
<input type="text" value=""/>	<input type="text" value=""/>	<input type="checkbox"/>	<input type="text" value=""/>	<input type="text" value=""/>

5. Enter split percentage values between 0 and 100.
6. Save the split percentages before entering percentages for a new range.
7. Save your work.

When you save split percentages, current date ranges displayed in the window can change as follows, depending on the effective and disable dates that you enter:

- When the co product definition is saved, for the time range from the date on which co product definition is created till infinite date in future. This is to ensure that split percentage can be found for a co product on any date after the co product is defined.
- When the effectivity date entered should be greater than the current date.
- If the new time range is overlapping with one or more existing time ranges, then the overlapping time range will have the split percentages entered against the new time range. Existing date ranges will be shortened so that the overlapping region falls under the new range.
- If any existing range completely overlaps the new range, then split percentage data for this range will be deleted.

**Note:** If you want to add a new Secondary co-product, then use the Define Co-products window. You cannot add a new secondary co-product from the Define Time Phased Split Percentages window. The Define Time Phased Split Percentages window only lets you modify the split percentage of exiting co-products.

## Substitute Components Window

### To define substitute components:

1. Navigate to the Define Co-products window.
2. Select an item number in the Component field.
3. Choose Substitutes.

The Substitute Components window displays.

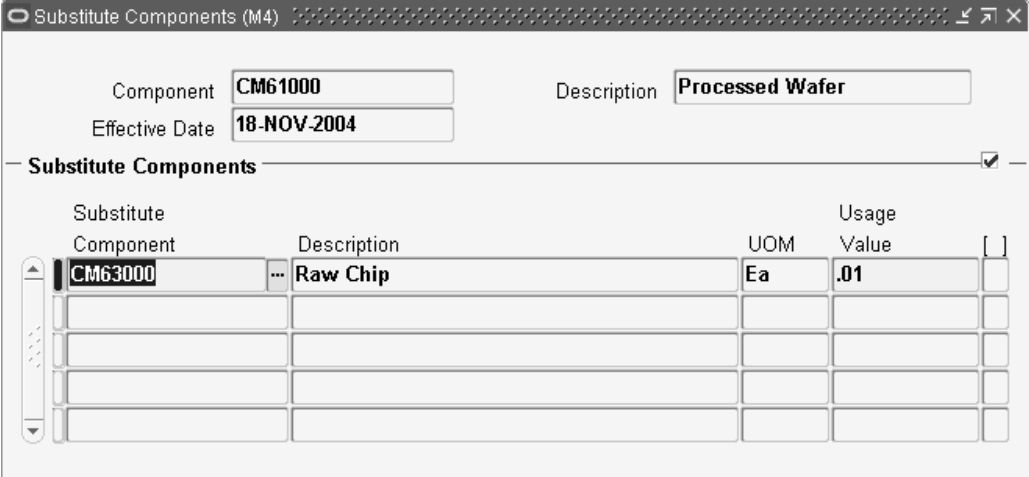

The screenshot shows the 'Substitute Components (M4)' window. At the top, there are input fields for 'Component' (CM61000), 'Effective Date' (18-NOV-2004), and 'Description' (Processed Wafer). Below these is a section titled 'Substitute Components' with a checked checkbox. This section contains a table with the following columns: 'Substitute Component', 'Description', 'UOM', and 'Usage Value'. The first row in the table is highlighted and contains the following data: 'CM63000', 'Raw Chip', 'Ea', and '.01'. There are four empty rows below the first one.

Substitute Component	Description	UOM	Usage Value
CM63000	Raw Chip	Ea	.01

4. Default information default displays component item number, description, effective date, and alternate bill of material.
5. In the Substitute Components region, enter the item number in the Substitute Component field, and the quantity used in the Usage Value field.
6. Save your work.

## Component Details Window

This window enables you to enter corresponding bill of material information for the component.

### To define component details:

#### To define component details:

1. Navigate to the Define Co-Products window.
2. Select an item number in the Component field.
3. Choose Details.

The Component Details window displays default information for the Planning Percent, Yield, Item Type, Status, and Include in Cost Rollup fields and check box.

The screenshot shows a window titled "Component Details (M4)". It contains the following fields and controls:

- Planning %: 100
- Yield: 1
- Item Type: Subassembly
- Status: Active
- Include In Cost Rollup
- Material Control** section:
  - Supply Type: Operation Pull
  - Subinventory: [empty]
  - Locator: [empty]
- Comments: [empty text area]

- In the Material Control region—the Supply Type field defaults to Operation Pull, and the Subinventory and Locator fields default to the values set up for this item number.

Optionally, you can update the Subinventory and Comments fields. In the Comments field you can enter a notation about information on this window. For example, a comment about why this part is not considered in a cost rollup if that check box is not marked.

**Note:** Co-product component details, once entered, are updated on the corresponding bill of material window.

---

# Costing in Oracle Shop Floor Management

*The Oracle Cost Management User's Guide* is a prerequisite for understanding this chapter. Since lot based jobs use Standard Costing, sections specific to other costing methods may be skipped.

This chapter covers the following topics:

- Overview of Lot Based Job Costing
- Cost Rollup for Network Routings
- Standard Cost Update for Lot Based Jobs
- Phantom Routings
- Lot Based Jobs Transaction Costing
- Move Transaction Costing
- Estimated Scrap Accounting
- Disabling Estimated Scrap and Operation Yield Accounting
- Non Standard Expense Lot Based Jobs
- WIP Lot Based Jobs Transaction Costing
- Lot Split Transactions
- Merge Lots
- Bonus Lots
- Update Quantity
- Update Routing and Update Assembly
- Lot Based Transaction are Integrated into Cost Manager
- Transaction Import through MES
- WIP Value Summary
- Reports

## Overview of Lot Based Job Costing

Many companies, such as those in the semiconductor industry, need to account for estimated scrap at each operation of a job. Operation yield is expressed as the compliment of the estimated scrap at each operation. When defining an item's

routing, you can enter operation yields at each operation on that routing, and specify whether that operation's yield is to be rolled up into the assembly cost.

The cost rollup includes this estimated yield loss absorption. During a lot's WIP execution, operation yield cost is charged to the lot. Any difference between estimated scrap absorption and actual scrap is tracked by operation and by department.

Oracle Shop Floor Management includes the following features:

- Define operation level yields on the routing of a product
- Collect actual yields for a lot at all the required operations
- Calculate yield loss as part of the cost of the product

## Related Topics

Defining Operation Yield Values on Routings, page 3-11.

Bills and Cost Rollups, *Oracle Cost Management User's Guide*.

Selecting and Item / Cost Type Association, *Oracle Cost Management User's Guide*.

## Cost Rollup for Network Routings

Cost Rollup considers material, overhead, and resource costs using the reverse cumulative yield as well as component and manufacturing shrinkage. The operation yield is factored into the rollup cost for the assembly if the Include in Rollup and the Operation Yield Enable flags are enabled for the operation on the routing. The operation is included in the cost rollup if the Include in Rollup flag is enable, irrespective of whether the operation lies on the primary or alternate path.

## Standard Cost Update for Lot Based Jobs

As in discrete jobs, Standard Cost Update revalues job balances , creates accounting adjustments and prints the adjustments along with the new job values in the standard cost WIP adjustment report. However, new department-based overheads are not added to prior operations for lot based jobs. These new overheads are only included in future operations on the job.

Adjustments to the job are generally offset by the standard cost adjustment account on the WIP accounting class. However, adjustments to WIP relieved value due to scrap in standard lot based jobs, are offset by the department actual scrap account. Also, the adjustment to the Estimated Scrap due to the standard cost update is offset by the department Estimated Scrap Absorption account. Standard Cost Update does not adjust existing jobs for changes made to the operation yield.

## Phantom Routings

The department on the phantom routing should be the same as the department of the operation that uses the phantom. This is important because estimated scrap accounting is based on the operation department.

Operation yields in phantom routing are not included (rollup) into the parent operation's yield. See: Phantoms in Lot Based Jobs, *Oracle Bills of Material User's Guide*.



## Lot Based Jobs Transaction Costing

There are seven types of WIP lot transactions available to lot based jobs including split, merge, update assembly, bonus, update routing, update quantity, and update lot number. Oracle Shop Floor Management enables you to include operation yields in the cost of an assembly for lot based jobs. During a lot's progression on the shop floor the following transactions require costing: move, scrap, split, merge, bonus, and update quantity.

## Move Transaction Costing

A move transaction moves assemblies within an operation, such as from queue to run, or from one operation to the next. Move transactions can automatically launch backflushing, charge resources and overheads. Manufacturing transactions created manually by the user, or due to backflush by the move processor, are costed similar to standard discrete jobs. See: Manufacturing Standard Cost Transactions, *Oracle Work in Process User's Guide*.

## Estimated Scrap Accounting

As the WIP Lot progresses through each operation in the job, the department tied to the operation receives credit as Estimated Scrap Absorption for additional cost due to the operation yield. The job is debited as Estimated Scrap for this same cost.

Consider an operation 10, department A, with operation yield of 70%. If 100 units were sent into operation 10 in order to produce 10 completed units, then at 100% yield, the unit cost of the assembly is assumed to be \$10. However, at the estimated yield of 70%, the unit cost is  $(100 * 10)/70$

Hence the additional cost per unit assembly due to operation yield is

$$(100*10)/70 - 10 = 10 * (1/0.7 - 1) = 10 * [(1-0.7)/0.7]$$

Estimated Scrap per unit = (Total operation cost per unit through the current operation + Total Estimated Scrap Cost per unit through the previous operation) \*  $[(1 - \text{op.yield})/\text{op.yield}]$

Dollars absorbed by the department due to good units completed in an operation = Estimated Scrap per unit \* Number of good units that passed through the operation.

The accounting entries for estimated scrap absorption transaction are:

Account	Debit	Credit
WIP Valuation Estimated Scrap Account	XX	
Department Estimated Scrap Absorption Account		XX

Consider a second operation 20 following operation 10 from the previous example:

Suppose that, out of the 70 good units that were sent into operation 20, 5 units were scrapped at operation 20. Since these have absorbed the additional cost due to estimated scrap in each of the previous operations (operation 10 in the present example), it is

essential to reverse the estimated scrap absorption that has been done for the scrapped units.

Net Reversal = (Total estimated scrap per unit through the previous operation) \* Number of units actually scrapped

---

<b>Account</b>	<b>Debit</b>	<b>Credit</b>
Department Actual Scrap Account	XX	
WIP valuation Estimated Scrap Account		XX

---

The assembly scrap is charged based on the job requirements to the actual scrap account defined for the department. See: *Assembly Scrap Transactions, Oracle Cost Management User's Guide*.

---

<b>Account</b>	<b>Debit</b>	<b>Credit</b>
Department Actual Scrap Account	XX	
WIP Valuation Accounts		XX

---

Completion transactions relieve the WIP Valuation Accounts of the accounting class and charge the inventory valuation accounts based on the assembly's standard cost (Frozen). The operation yield cost is relieved from the Estimated Scrap Account.

<b>Account</b>	<b>Debit</b>	<b>Credit</b>
INV Valuation Material Account	7.0	
INV Valuation Material Overhead Account	1.2	
INV Valuation Resource Account	3.5	
INV Valuation Overhead Account	2.3	
INV Valuation Outside Processing Account	2.0	
WIP Valuation Material Account		6.0
WIP Valuation Material Overhead Account		1.0
WIP Valuation Resource Account		3.0
WIP Valuation Overhead Account		2.0
WIP Valuation Outside Processing Account		1.0
WIP Valuation Estimated Scrap Account		3.0

**Note:** The WIP Estimated Scrap is allocated to the five INV accounts.

As in discrete jobs, the job close process writes off any remaining balances in the WIP Valuation Accounts to the respective variance account. The balance in the Estimated Scrap Account is written off the accounting class Estimated Scrap Variance Account.

<b>Account</b>	<b>Debit</b>	<b>Credit</b>
WIP Estimated Scrap Variance Account	XX	
WIP Valuation Estimated Scrap Accounts		XX

The estimated scrap variance is primarily caused by deviations from the standard BOM or Routing. The difference between the estimated scrap absorption and actual scrap is the indicator reflecting the department's performance.

## Disabling Estimated Scrap and Operation Yield Accounting

In some industries, such as the metals industry, there is no need to do estimated scrap absorption accounting as the scrapped items may be reused as a separate product. In addition, there may be no need to relieve cost from the job at the time of scrap.

You can choose to disable estimated scrap accounting for any organization to simplify accounting setups and variance analysis. The Estimated Scrap Accounting flag is on the Shop Floor Parameter window. You can change the value on this field only if all lot based jobs are in one of the following statuses - Unreleased, Closed, On hold, or Canceled.

If this field is set to enabled, the scrap transaction cost is relieved from the job and the scrap account is required on the Departments window. Estimated Scrap Accounting is performed as the job is moved from one operation to the next.

When it is set to disabled, there is no Estimated Scrap Accounting. The Estimated Scrap Absorption and the actual Scrap accounts are not required on the Departments window. Other aspects of this feature include:

- You may rollup cost into an updateable Cost Type with or without operation yield costing.
- The Assembly Cost Rollup does not change because cost is calculated based on the Include In Rollup and Operation Yield Enabled flags in the network routing. These flags are independent to the Estimated Scrap Accounting decision.
- If the standard cost (Frozen Cost Type) is based on operation yield costing, the estimated scrap cost is included in the five cost elements for both Inventory Valuation and job completion costing. There will be no credit to the WIP Estimated Scrap Account for Assembly Completion transactions.
- At the time of the scrap transaction, you can enter a scrap account on the Move Lot Based Jobs window to relieve costs from the work order. Generally, if your standard cost is based on Yield Costing, you will not provide a scrap account and leave the scrap in the job. If your standard cost is not based on Yield Costing, you will provide a scrap account and the job will be relieved of scrap. In either case, the quantity scrapped in the operation is updated.
- The operation yield costing and scrap costing decision should be the same for an item. This consistency will reduce variance. However you may decide differently for different items.

## Non Standard Expense Lot Based Jobs

Consider the following when working with non standard expense lot based jobs.

- Non Standard Expense Lot Based Jobs disable Estimated Scrap accounting whether or not Estimate Scrap accounting is enabled at the Inventory Organization level.
- Non Standard Expense Discrete Jobs are not earn Material Overhead on completion, and is not be revalued by standard cost update.
- Unlike Non Standard Expense Discrete Jobs, variances in Non Standard Expense Lot Based Jobs are not flushed out at period close.
- You can perform WIP lot transactions on non standard lot based jobs. The costing of these transactions is similar to that of standard lot based jobs.

## WIP Lot Based Jobs Transaction Costing

There are seven types of WIP lot transactions available to lot based jobs including split, merge, update assembly, bonus, update routing, update quantity, and update lot number. WIP Lot Transaction can be done at the queue or to move intra-operation steps. However, it is not recommended that scrap transactions followed by WIP Lot transactions be performed at the queue intra-operation step.

**Note:** Performing scrap transactions in a separate operation allows for more intuitive costing.

During a lot's progression on the shop floor the following transactions have costing implications:

- Lot Split Transactions
- Lot Merge Transaction
- Bonus Transactions
- Update Quantity Transactions

Lot Based charges include lot based resources, lot based departmental overheads, and resource based overheads based on lot based resources.

## Lot Split Transactions

When you divide a single parent lot into multiple child lots, the actual costs of materials and resources issued to the parent lot (including lot based resources and overheads) are reallocated to the child lots, based on the quantity ratios. The actual costs (the net value remaining in the parent lot) are reallocated to the child lots on a sub-elemental basis. If the net value for any sub-element is negative, it is not reallocated to the child lots and is remain in the parent.

At the time of a split, WIP Lot Spit transactions are created, that will adjust the WIP value of the parent lot and resulting lots with the appropriate balance.

Consider a lot A of size 10 with material charges of \$100, items based resource charges of \$50, and lot based resource charges of \$50. One item is scrapped, resulting in a relief of \$20.

The net balance in lot A is  $(\$200 - \$20) = \$180$ .

If this lot were split into lot B of size 4 and lot C of size 5, the net balance is proportionally reallocated to the child lots. The parent receive a credit of \$180, and the children receive a debit based on the quantity ratio:

Lot B receive a debit of  $(4/9) * \$180 = \$80$

Lot C receive a debit of  $(5/9) * \$180 = \$100$

The accounting entries are:

Account	Debit	Credit
WIP Valuation Accounts for resulting lots	XX	
WIP Valuation Accounts for starting lot		XX

The estimated scrap absorption in the parent is reversed for the charge that has been reallocated to the child lots. Each child lot receive a debit for the additional cost due to operation yield based on the charge that has been reallocated to it.

For the starting lot:

Account	Debit	Credit
Department Estimated Scrap Absorption Account	XX	
WIP Valuation Estimated Scrap Accounts		XX

For resulting lot:

Account	Debit	Credit
WIP Valuation Estimated Estimated Scrap Account	XX	
Department Estimated Scrap Absorption Accounts		XX

**Note:** Cost incurred by the scrapped quantity remain in lot A.

## Merge Lots

When combining several lots into a single existing lot, the cost of materials and resources is reallocated to the resulting lot. The cost is proportionately reallocated to the resulting lot, based on the costs incurred by the representative lot. The net value in the representative lot is reallocated to the resulting lot on a sub-element basis. If the net value for any sub-element is negative, it is not reallocated to the resulting lot and will remain in the parent.

The lot based charges are not proportioned and the resulting lot incur the same lot based charges as the representative lot. Lot based charges incurred by the non-representative lots are not charged to the resulting lot.

Consider a lot A of size 10 with a material charge of \$100, item based resource charges of \$50. In addition, A has a charge of \$100, which is incurred because component E was pushed to the lot.

Consider a lot B of size 10 with a material charge of \$100, item based source charges of \$50, and lot based resource charges of \$50. In addition, B has a charge of \$200, which it incurred because a different component F was pushed to the lot.

Merge lot A and B into a lot C of size 20. Choose A as the representative lot.

Since A is the representative lot, all charges in C are based on charges incurred by lot A. Hence lot C will receive a debit of:  $[(20/10) * (\text{item based charged})] + (\text{lot based charges}) = [(20/10) * (\$250)] + (\$50) = \$550$ .

Lot A receive a credit of:  $(10/20) * \$500 + \$50 = \$300$

Lot B receive a credit of:  $(10/20) * \$500 = \$250$

The additional charges of \$200 that was incurred by lot B, but not by lot A, remain in lot B. The lot based charges incurred by B is not charged to the resulting lot and remain in lot B. Lot B therefore have a net balance of \$150.

The accounting entries are:

Account	Debit	Credit
WIP Valuation Accounts for resulting lot	XX	
WIP Valuation Accounts for starting lots		XX

The estimated scrap absorption in the starting lots are reversed for the charge that has been reallocated to the resulting lot. The resulting lot absorb the additional cost due to operation yield based on the charge that has been reallocated to it.

For the starting lots:

Account	Debit	Credit
Department Estimated Scrap Absorption Account	XX	
WIP Valuation Estimated Scrap Accounts		XX

For the resulting lot:

Account	Debit	Credit
WIP Valuation Estimated Scrap Account	XX	
Department Estimated Scrap Absorption Account		XX

## Bonus Lots

You can create bonus lots to perform operations on assemblies that were previously scrapped. The quantity starts in the intra-operation step of queue of the starting

operation. Therefore, components at the starting operations are not automatically charged when the bonus lot is created. The standard cost of the assembly through the previous operation is credited to the bonus account. The account is often the scrap account. Operation yield is calculated for all previous operations, based on standards.

Consider an assembly A with a component B (\$10) and a resource R1 (\$2) at operation 10. It also has a component C (\$20) and a resource R2 (\$1) at operation 20.

Create a bonus lot, lot-A of size 10 at operation 20. The lot incur all charges in operation 10. Since the lot is at the intra-operation step of queue at operation 20, charges in operation 20 is not included in the bonus lot.

Hence lot-A incur a charge of:  $10 * \$10 + 10 * \$2 = \$120$ .

The accounting entries are:

Account	Debit	Credit
WIP Valuation Accounts for bonus lots	XX	
Bonus Account (user specified)		XX

The bonus lot also receive a debit for the additional cost due to operation yield based on the charge that it has incurred.

Account	Debit	Credit
WIP Valuation Estimated Scrap Account	XX	
Bonus Account (user specified)		XX

## Update Quantity

You can increase the quantity remaining in a job using the update quantity transaction. Cost incurred by the job (except lot based cost) will be proportionately debited to the job, based on the new quantity and the net value remaining in the job. The net value remaining in the parent job is reallocated on a sub-elemental basis. If the net value for any sub-element is negative, it is not reallocated to the resulting lot.

The lot based charges are not proportioned in the update lot.

The credit is to the account specified while creating the update quantity transaction and is often the scrap account.

Consider a lot A of size 10 with a material charge of \$100, lot based resource charge of \$50, and resource based overhead charges of \$20 from overheads associated to the lot based resources.

Update the quantity in lot A to 20.

The cost incurred in the new lot is:  $[\$100 * (20/10) + \$50 + \$20 = \$270$

The non-lot based charges of \$100 are proportioned. The remaining lot based charges are not proportionate and remain in the job. Hence lot A receive a credit of \$100.

The accounting for the new charges to the job are:



Account	Debit	Credit
WIP Valuation Account	XX	
Bonus Account (user specified)		XX

The updated lot also receive a debit for the additional cost due to operation yield based on the additional charge that it has occurred.

The accounting entries are:

Account	Debit	Credit
WIP Valuation Estimated Scrap Account	XX	
Bonus Account (user specified)		XX

## Update Routing and Update Assembly

While performing update routing or update assembly transactions at the queue intra-operation step, if you have manual resources and overheads or push component on the current operation, you must manually reverse the charges.

## Lot Based Transaction are Integrated into Cost Manager

All transactions for the lot based jobs, including WIP lot transactions, are costed by the cost manager. In the sequence in which they occurred. If costing fails for any of these transactions, all subsequent transactions for lot based jobs in that organization will be suspended until that error is corrected.

## Transaction Import through MES

To correctly cost WIP lot transactions, it is essential to cost the transactions in a sequence. The cost manager sequentially cost all transactions based on the date on which they occurred. However, if a transaction with a prior date is imported through MES, there is a possibility that some subsequent WIP lot transactions on the job have already been costed. The WIP lot transactions are not reflex the late transactions.

If this timing problem is significant, you can use the date cutoff feature to shut off the cost manager until all relevant transaction on the job have been imported. You can set the date cutoff to process for anytime range you wish. This way all transactions are correctly processed in sequence. See: *Cost Manager, Oracle Cost Management User's Guide*.

## WIP Value Summary

You can use the WIP Value Summary window to view cost elements, if transaction related to the job have been costed. The estimated scrap cost incurred and relieved is displayed in the Operation Yield tab. You can also drill down to the detailed accounting distributions that contributed to the WIP value.

## Reports

The work in process reports enable you to view calculations of estimated scrap incurred, estimated scrap relieved, and estimated scrap variances on lot based jobs, in addition to the five cost elements (Material, Material Overhead, Resource, Overhead, Outside Processing). See: Discrete Job Value Report, *Oracle Work in Process User's Guide*.

You can analyze these cost by work order, as well as track departmental performance using the discrete job value report. See: WIP Value Report, *Oracle Work in Process User's Guide*.

## Related Topics

Manufacturing Resources, *Oracle Advanced Supply Chain Planning*, *Oracle Risk Optimization*, and *Oracle Global Order Promising User's Guides*.

Items, *Oracle Advanced Supply Chain Planning*, *Oracle Risk Optimization*, and *Oracle Global Order Promising User's Guides*. Constraint Types, *Oracle Advanced Supply Chain Planning*, *Oracle Risk Optimization*, and *Oracle Global Order Promising User's Guides*.

*Oracle Advanced Supply Chain Planning*, *Oracle Advanced Supply Chain Planning*, *Oracle Risk Optimization*, and *Oracle Global Order Promising User's Guides*.

---

## Closing Lot Based Jobs

This chapter covers the following topics:

- Closing Lot Based Jobs
- Unclosing Lot Based Jobs
- Purging Lot Based Job Move Transactions

### Closing Lot Based Jobs

You can close lot based jobs using the Close Lot Based Jobs (Form) window or the Close Lot Based Jobs Submit Requests (SRS) window. The choice depends on your requirements.

The Close Lot Based Jobs (Form) window enables you to:

- Submit and process lot based job close requests
- Specify the actual close date, this can be different than the transaction date
- View the pending transaction summaries before closing
- Using summary form you can close multiple lot based jobs

The Close Lot Based Jobs Submit Requests window enables you to:

Submit the concurrent request to close the lot based job. To use the request option, you need to specify the parameter using different criteria like set of jobs, release date, job status, actual close date. This provides the ability to close the multiple lot based jobs

The business requirements for closing the lot based job using forms or reports are the same. You cannot close a job that has pending material, resource, or move transactions including those that the concurrent manager has not processed. Also you cannot close a job that has unclosed material transactions. Prior to closing lot based jobs, you can review job value information using the Job Value Report, which lists standard and non-standard asset jobs, or the Expense Job Value Report, which lists non-standard expense jobs. You can also see the summary of pending transaction while using Lot Based Jobs close using forms.

### To close a lot based job using the Close Lot Based Jobs window:

1. Navigate to the Close Lot Based Jobs window.

The Find Lot Based Jobs window displays.

Find Lot Based Jobs (WSM)

Jobs [ ] - [ ]

Type [ ]

Assembly [ ]

Schedule Group [ ]

Build Seqs [ ] - [ ]

Class [ ]

Start Dates [ ] - [ ]

Completion Dates [ ] - [ ]

Status

Unreleased  Released

Complete  On Hold

Closed [ ]

Clear Find

2. Enter your criteria and choose Find.

The Close Lot Based Jobs Summary window displays.

3. Select a job, or multiple jobs, and choose Open to display the Close Lot Based Jobs window.

You can only close jobs with statuses of Cancelled, Complete, Complete – No Charges, Failed Bill Load, Failed Close, Failed Routing Load, On Hold, Released, and Unreleased.

4. Select Transaction Summary from the Tools menu to view all pending transactions.

Only jobs without pending transactions can be closed.

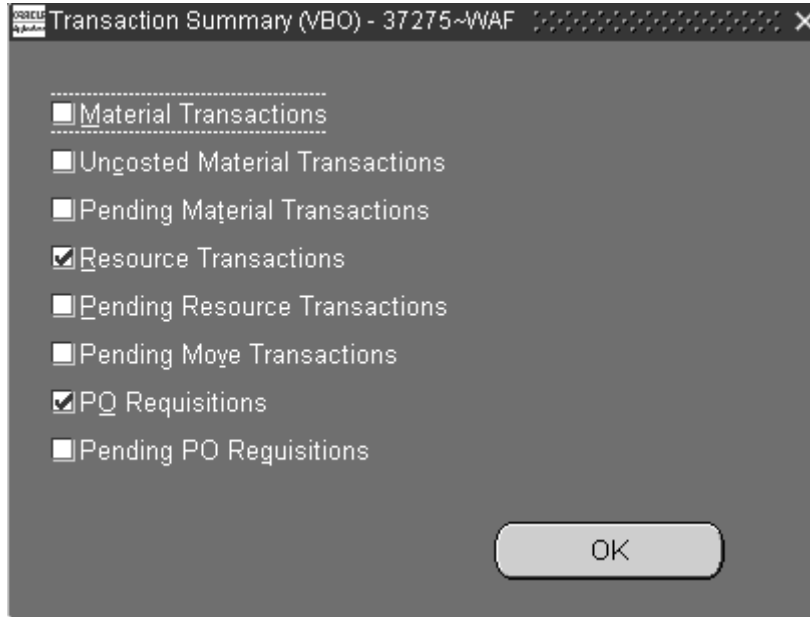

5. Select Close from the Tools menu to display the Close Lot Based Jobs Request window. This window is used to select close options.

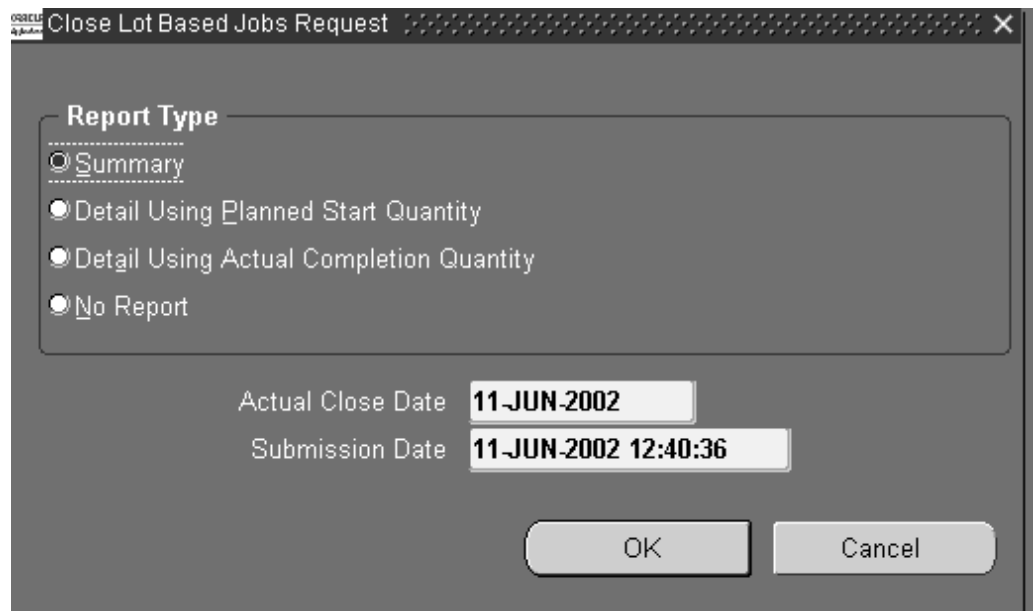

6. Select a report type.

Reports are printed, per the Report Type specified, after the close process computes job close variances. The Discrete Job Value Report – Standard Costing is printed when standard lot based jobs and non-standard asset jobs are closed. The Expense Job Value Report is printed when expense non-standard jobs are closed. Report Type options and formats are as follows:

- *Summary*: Lists each job and includes job header, period-to-date summary, and cumulative-to-date summary information.

- *Detail Using Planned Start Quantity:* Lists each job using the planned start quantity of the job to calculate the material usage variance.
  - *Detail Using Actual Completion Quantity:* Lists each job using the actual completion quantity of the job to calculate the material usage variance.
  - *No Report:* Does not print a report.
7. Select an Actual Close Date, the system date is the default.
  8. Select a Submission Date and time, the system date and time is the default.
  9. Choose OK to submit this request.

Only those jobs with appropriate statuses are closed. The statuses of jobs that are being closed are changed to Pending Close until the close process completes.

### To close a lot based job using Submit Requests:

Navigate to the Close Lot Based Jobs (SRS) window. The Parameters window appears.

The screenshot shows a 'Parameters' dialog box with the following fields and values:

- Class Type: [Empty]
- From Class: [Empty]
- To Class: [Empty]
- From Job: [Empty]
- To Job: [Empty]
- From Job Release Date: [Empty]
- To Job Release Date: [Empty]
- From Job Start Date: [Empty]
- To Job Start Date: [Empty]
- From Job Completion Date: [Empty]
- To Job Completion Date: [Empty]
- Status: Complete - No Charges
- Exclude Reserved Jobs: Yes
- Exclude Un-Completed Jobs: Yes
- Exclude Jobs with Pending Trans: Yes
- Report Type: Summary
- Actual Close Date: 26-MAR-2003

Buttons at the bottom: OK, Cancel, Clear, Help.

10. Select an accounting class in the Class Type field, or range of accounting classes in the From and To Class fields.

The options are Standard discrete, Asset non– standard, or Expense non– standard. If you do not select a class type, the system closes job for all class types.

If you select a class type, you can only select accounting classes of that class type. If you do not select a To Class, all jobs from the From Class forward are closed. If you do not select a From Class, all jobs through the To Class are closed.

11. Select a range of lot based jobs to close in the From and To Job fields.

If this field is left blank, all jobs that fit the close requirements are closed.

12. You can select a range of job release dates, job start dates, job completion dates in the From and To fields.
13. Select a job Status.  
You can only close jobs with one with the following statuses: Cancelled, Complete, Complete – No Charges, Failed Bill Load, Failed Close, Failed Routing Load, On Hold, Release, or Unreleased.
14. Exclude Reserved Jobs parameter gives you the option to exclude or include jobs linked to sales orders from the processing.
15. Exclude Un– Completed jobs parameter, gives you the option to exclude or include jobs having a status other than Complete from the processing.
16. Enter Yes in the Exclude Jobs with Pending Transactions field. If you enter Yes, then the application excludes jobs having pending transactions.
17. Select a Report Type

Reports are printed, per the Report Type specified, after the close process computes job close variances. The Discrete Job Value Report – Standard Costing is printed when standard lot based jobs and non–standard asset jobs are closed. The Expense Job Value Report is printed when expense non–standard jobs are closed. Report Type options and formats are as follows:

- *Summary*: Lists each job and includes job header, period– to– date summary, and cumulative– to– date summary information.
  - *Detail using planned start quantity*: Lists each job using the planned start quantity of the job to calculate the material usage variance.
  - *Detail using actual completion quantity*: Lists each job using the actual completion quantity of the job to calculate the material usage variance.
  - *No Report*: Does not print a report.
- 18. Choose OK to submit the request.

See: Running Reports and Programs, *Oracle Applications User's Guide*.

## Related Topics

Overview of Function Security, *Oracle Applications System Administrator's Guide*

Discrete Job Value Report, *Oracle Work In Process User's Guide*

## Unclosing Lot Based Jobs

You can use the Unclose Lot Based Jobs window to reopen jobs that are closed. You cannot unclose a job that does not have a status of Closed. This function is not available if the job was closed in an accounting period that is currently closed.

Information associated with a job is not deleted when the job is closed. You can view information for closed discrete jobs. You cannot purge Lot Based Job record. You also can print reports on closed jobs and closed job values. See: Discrete Job Data Report, *Oracle Work in Process User's Guide*. Discrete Job Value Report, *Oracle Work in Process User's Guide*.

**Note:** Only jobs closed in error should be unclosed, and this should be done immediately after the close. If assembly costs are rolled up between the time you close then unclose a job, your costs may be incorrect because the unclosure process does *not* revalue the job.

### To unclosure a lot based job:

1. Navigate to the Unclose Lot Based Jobs window.  
The Find Lot Based Jobs window displays.
2. Enter your criteria and choose Find.  
The Unclose Lot Based Jobs Summary window displays.
3. Select a job, or multiple jobs, and choose Open to display the Unclose Lot Based Jobs window.

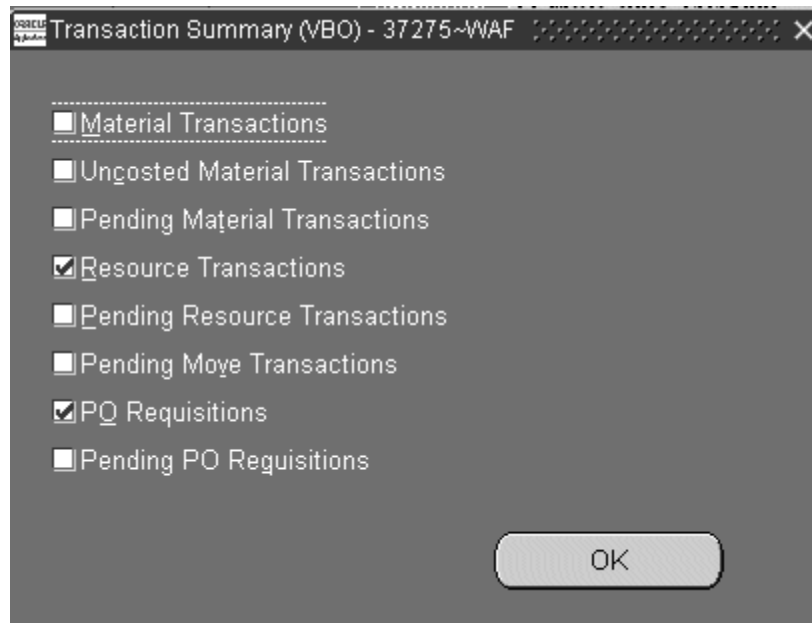

4. Select Transaction Summary from the Tools menu to view all pending transactions.
5. Select Unclose from the Tools menu.  
A Decision window displays prompting you about proceeding with this action.



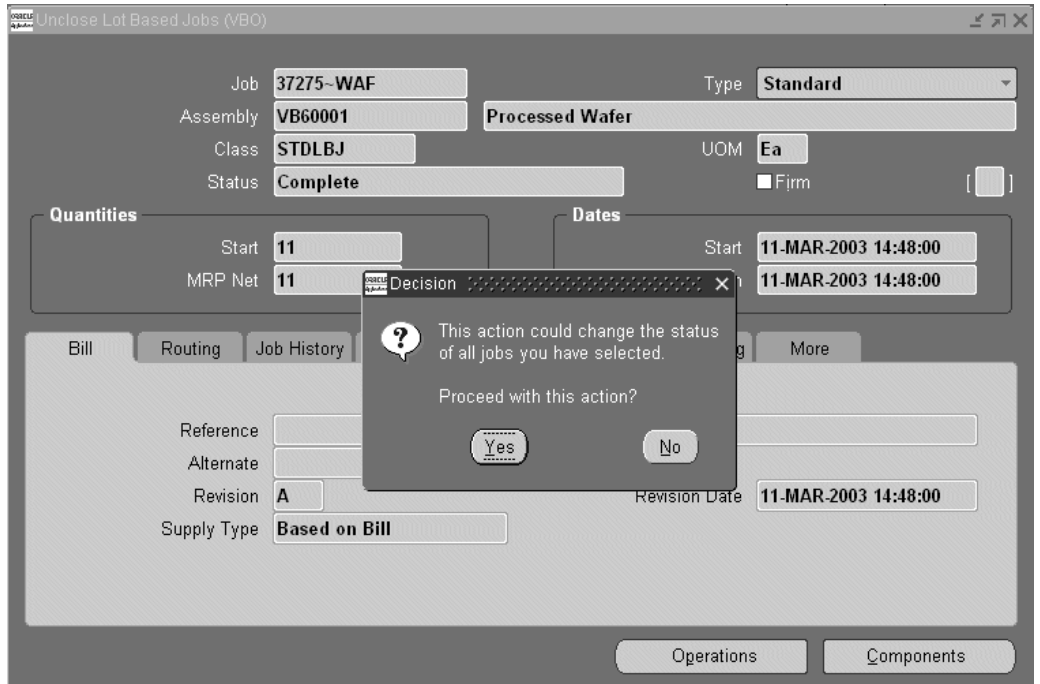

6. Choose Yes to unclose your job.

## Purging Lot Based Job Move Transactions

You can purge data related to move transactions of historical jobs based on specific parameters from a closed accounting period using the Purge Lot Based Jobs concurrent program. Genealogy links are preserved by retaining all header information for each job and WIP lot transactions such as split and merge.

### To purge lot based job transactions:

1. Navigate to the Purge Lot Based Jobs Parameters window.
2. Job type defaults to Lot Based Jobs.

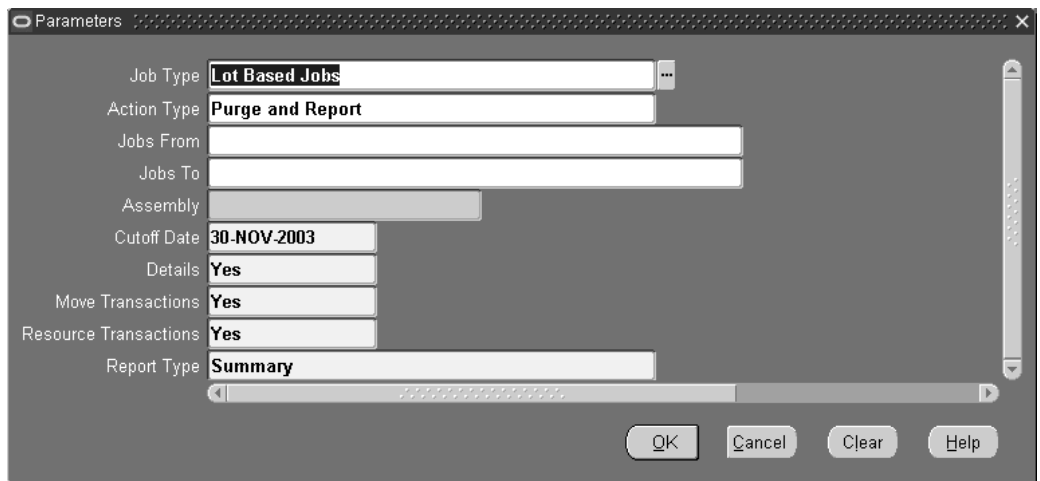

3. Enter the Action Type.
4. Enter the Jobs From and Jobs To fields to define a range of lot based jobs to purge.
5. Enter the Assembly.
6. Enter the Cutoff date for the closed inventory accounting period.
7. Enter purge selection criteria. If you choose to purge headers, then Details, Move Transactions, and Resource Transactions fields default to Yes.
8. Enter the Report Type.
9. Choose OK. The Purge Lot Based Jobs window displays request details.
10. Choose Submit to run this request.

---

## Windows and Navigator Paths

This appendix covers the following topics:

- Windows and Navigator Paths

### Windows and Navigator Paths

The following table shows how to find detailed information described in other manuals.

Advanced Supply Chain Planning	Refer to the Oracle Advanced Supply Chain Planning, Oracle Risk Optimization, and Oracle Global Order Promising User's Guide
BOM	Refer to the Oracle Bill of Materials User's Guide
Inventory	Refer to the Oracle Inventory User's Guide
Quality	Refer to the Oracle Quality User's Guide
User	Refer to the Oracle Application User's Guide
WIP	Refer to the Oracle Work in Process User's Guide

The following table shows windows and navigation paths for Oracle Shop Floor Management.

Window Name	Navigation Path
Alternates	Shop Floor > Routings > Alternates BOM > Setup > Alternates
Calculate Cumulative Yield for Network Routing	Shop Floor > Run Requests
Close Lot Based Jobs	Shop Floor > Lot Transactions > Close Lot Based Jobs Close Lot Based Jobs (Form)
Component Details	Shop Floor > Co-Products > Define Co-Products > Details

<b>Window Name</b>	<b>Navigation Path</b>
Component Pick Release	Shop Floor > Lot Transactions > Component Pick Release > Find Lot Based Jobs
Departments	Shop Floor > Routings > Departments BOM > Routings > Departments
Lot Based Jobs	Shop Floor > Lot Based Jobs > Find Lot Based Jobs
Lot Based Transaction Cost Manager	Shop Floor > Run Requests > Lot Based Transaction Cost Manager
Lot Based Jobs Summary	Shop Floor > Lot Based Jobs > Find Lot Based Jobs > Find
Lot Creation	Shop Floor > Lot Transactions > Lot Creation
Define Co-Products	Shop Floor > Co-Products
Inventory Lot Transactions	Shop Floor > Lot Transactions > Inventory Lot Transactions
Lot Creation	Shop Floor > Lot Transactions > Lot Creation
Lot Genealogy	Shop Floor > Lot Genealogy > Find Lots/Jobs > Jobs Summary > View Genealogy >
Material Requirements	Shop Floor > Lot Based Jobs > Find Lot Based Jobs > Lot Based Jobs > Components
Move Lot Based Jobs	Shop Floor > Lot Transactions > Move Transactions
Operation Resources	Shop Floor > Network Routings > Routings > Operation Resources
Operations	Shop Floor > Lot Based Jobs > Find Lot Based Jobs > Lot Based Jobs > Operations
Personal Profile Values	Shop Floor > Other > Profile
Resource Transactions	Shop Floor > Lot Transactions > Resource Transactions WIP > Resource Transactions > Resource Transactions
Routing Details	Shop Floor > Network Routings > Routings > Routing Details
Routing Network	Shop Floor > Network Routings > Routings > Network Routing
Routings	Shop Floor > Network Routings
Sector Extensions and Item/Subinventory Association	Shop Floor > Setup > Sector Extensions > Find Sector Extension

<b>Window Name</b>	<b>Navigation Path</b>
Shop Floor Management Parameters	Shop Floor > Setup > Parameter
Standard Operations	Shop Floor > Routings > Standard Operations
Standard Operation Details	Shop Floor > Setup > Operation Details
Substitute Components	Shop Floor > Co-Products > Define Co-Products > Substitutes
Substitute Co-Products	Shop Floor > Co-Products > Define Co-Products > Co-Product Substitutes
WIP Lot Transactions	Shop Floor > Lot Transactions > WIP Lot Transactions
WIP Lot Transactions Processor	Shop Floor > Run Requests > WIP Lot Transactions Processor
WIP Value Summary	Shop Floor > Lot Transactions > View Transactions > WIP Value Summary



## Symbols

30 character limit, 4- 5

---

### C

Co Products Supply Default, 2- 8

Co-products, 1- 6

defining, 7- 1

overview, 7- 1

Component Details window, 7- 5

Component picking transactions for lot based jobs, 1- 7

Cost rollup

routing, 8- 2

---

### D

Default Accounting Class, 2- 8

Defining

lot sector extension codes, 2-12

parameters, 2- 7

standard operation details, 2-13

---

### E

Estimated scrap accounting, enabling and disabling, 2- 9

---

### I

Inventory Lot Transactions API, enabling, 2- 9

---

### L

License plate numbers, 1- 8

Lot based jobs

creating, 4- 2

resources, viewing, 4-13

status, viewing, 4-13

transaction costing, 8- 3 , 8- 7

view component requirements, 4- 7

view lot attributes, 4- 8 , 4-11

Lot based transaction cost manager, 8-11

Lot Creation window, 4-28

Lot Genealogy, 1- 5

genealogy view, 6- 2

overview, 6- 1

where-used view, 6- 2

Lot Genealogy overview, 6- 1

Lot move transactions

creating, 4- 9

Lot moves

overview, 4- 8

Lot sector extensions, 2-11

Lot Separator field, 2- 7

Lot transactions, 1- 5

Lots

assigning starting operation for child lots, 4-21

bonus, 4-20, 4-21

enhanced functionality, 1- 5

genealogy, 1- 5

merging, 4-20, 4-21, 4-26

move transactions, 4- 9

splitting, 4-20, 4-21, 4-26

transaction costing, 8- 3 , 8- 7

transactions, 1- 5

transfer, 4-20

transferring, 4-26

translating, 4-26

update assembly, 4-20, 4-21

---

### M

Multilevel bill of material, 1- 2

---

### N

Network routings, 1- 4

adding and changing, 3- 8

calculating cumulative yield and reverse

cumulative yield, 3-13

creating, 3- 4 , 3- 5

defining yield values, 3-11

deleting, 3- 9

flow illustration, 3- 2

overview, 3- 1

Non-standard lot based jobs, 4- 3

---

### O

Operation jumps, 4-12

Operation yield

- defining values on routings, 3-11
- overview, 8- 1
- Operation yields, 1- 6
- Oracle Advanced Supply Chain Planning Integration
  - network routings, 3-13
- Outside Processing Integration
  - network routings, 4-33
- Overview
  - co-products, 7- 1
  - lot moves, 4- 8
  - network routings, 3- 1
  - of lot transactions, 4- 2
  - setting up, 2- 1
  - Shop Floor Management, 1- 1

## **P**

---

- Phantom assemblies, 1- 2
- Profile option, Allow operation jumps, 2-15
- Profile option, WSM
  - Allow Operation Jumps, 2-16
  - Complete Job Sector Lot Extension Level, 2-17
  - Delete successfully processed move transaction, 2-17
  - Maximum Number of Import Lot Job Workers, 2-17
  - Maximum Number of Rows Processed by a Lot Based Job Worker as a Batch, 2-17

## **R**

---

- Representative Lot check box, 4-24

- Routing Network window, 3- 5

## **S**

---

- Setup
  - checklist, 2- 3
  - flowchart, 2- 2
  - related product setup steps, 2- 2
- Shop Floor Management flow, 1- 2
- Standard cost update, 8- 2
- Standard Operation Details, 2-13
- Standard Operation Details window, 2-13
- Substitute Components window, 7- 5

## **U**

---

- Undo Last Move, 2- 8 , 4-10

## **W**

---

- WIP lot bonus transactions
  - creating, 4-23
- WIP lot merge transactions
  - creating, 4-24
- WIP lot split transactions
  - creating, 4-24
- WIP lot transactions, 4-21
  - creating, 4-22
- WIP lot update transactions, 4-25
- WIP value summary, 8-11





